

# Manual motor starter MS165

Manual motor starters are electro-mechanical protection devices for the main circuit mainly used to switch motors manually ON/OFF and protect them fuseless against short-circuit, overload and phase failures. Fuseless protection with a manual motor starter saves costs, space and ensures a quick reaction under short-circuit condition, by switching off the motor within milliseconds. Fuseless starter combinations are setup together with contactors.

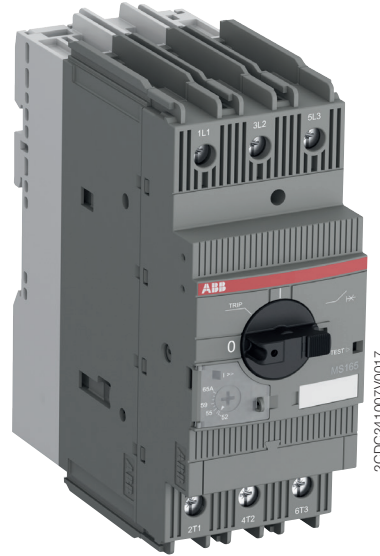

## Description

- Overload protection – trip class 10
- Phase loss sensitivity
- Disconnect function
- Temperature compensation from -25 ... +60 °C
- Adjustable and sealable current setting for overload protection
- Suitable for three- and single-phase applications
- Trip-free mechanism
- Status indication for short-circuit trip
- Clear switch position indication ON/OFF/TRIP
- Lockable handle

## Order data

MS165 screw terminal



Setting range	Trip class	Type	Order code	Packing unit	Weight per pc
A				pc	kg
10 ... 16	10	MS165-16	1SAM451000R1011	1	0.95
14 ... 20	10	MS165-20	1SAM451000R1012	1	0.95
18 ... 25	10	MS165-25	1SAM451000R1013	1	0.96
23 ... 32	10	MS165-32	1SAM451000R1014	1	0.97
30 ... 42	10	MS165-42	1SAM451000R1015	1	0.97
40 ... 54	10	MS165-54	1SAM451000R1016	1	0.97
52 ... 65	10	MS165-65	1SAM451000R1017	1	0.98

## Functional description

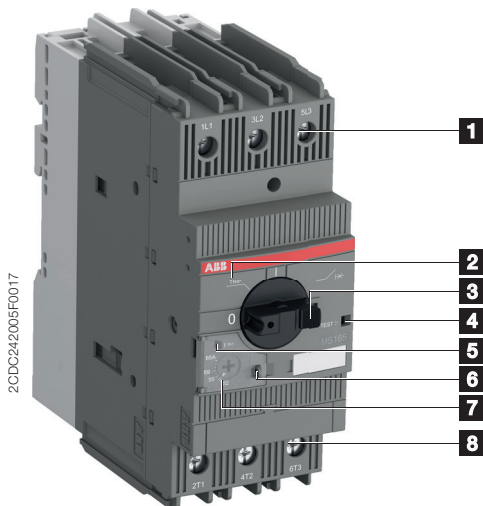

- 1** Terminals 1L1, 3L2, 5L3
- 2** Switch position TRIP
- 3** Lockable handle
- 4** Test function
- 5** Status indication for short-circuit
- 6** Sealable cover
- 7** Current setting range / Adjustable current setting for overload protection
- 8** Terminals 2T1, 4T2, 6T3

## Application

The manual motor starters protect the load and the installation against short-circuit and overload. They are three pole protection devices with thermal tripping elements for overload protection and electromagnetic tripping elements for short-circuit protection. Furthermore, they provide a disconnect function for safe isolation of the installation and the supply and they can be used for manual switching of loads.

The manual motor starters have a setting scale in amperes, which allows the direct adjusting of the device without any additional calculation. In compliance with international and national standards, the setting current is the rated current of the motor and not the tripping current (no tripping at  $1.05 \times I$ , tripping at  $1.2 \times I$ ;  $I$  = setting current).

## Operation mode

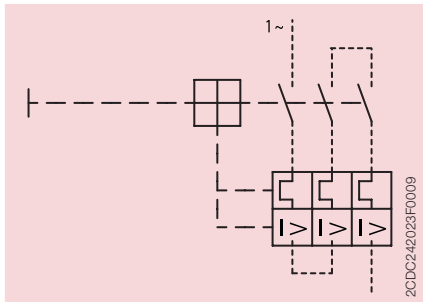

Single-phase operation

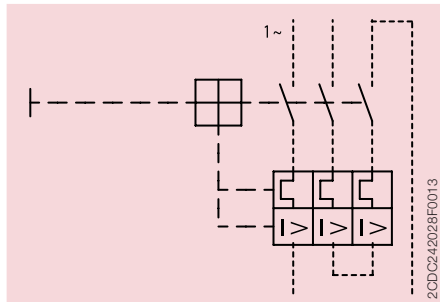

Single-phase operation

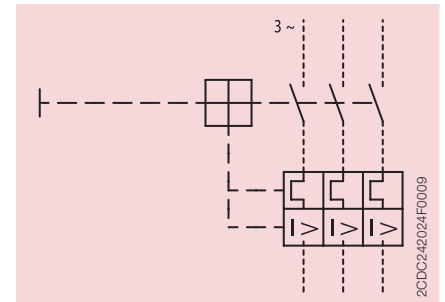

Three-phase operation

## Wiring diagram

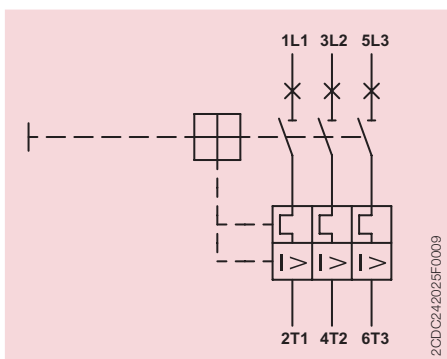

## Resistance and power loss per pole

Type	Setting range		Resistance per pole mΩ	Power loss per pole at lower value		Power loss per pole at upper value W
	lower value A	upper value A		W	W	
MS165-16	10	16	14.9	1.49	3.81	
MS165-20	14	20	9.3	1.82	3.72	
MS165-25	18	25	5.8	1.88	3.6	
MS165-32	23	32	4.3	2.27	4.4	
MS165-42	30	42	3.1	2.79	5.47	
MS165-54	40	54	2.4	3.84	6.99	
MS165-65	52	65	1.9	5.14	8.02	

## Technical diagram

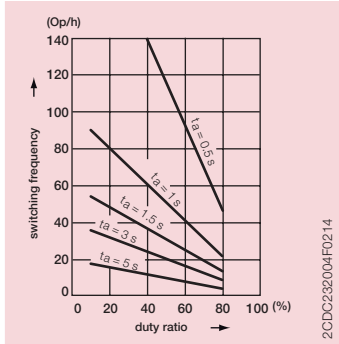

Intermittent periodic duty,  $t_a$ : Motor starting time

## Dimensions

in mm / inches

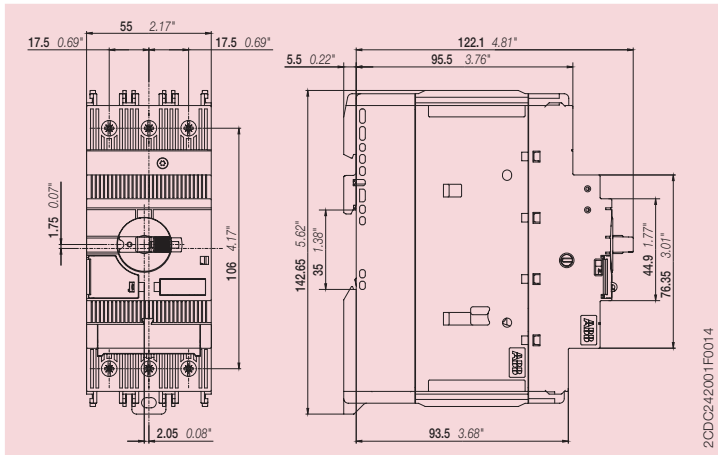

MS165

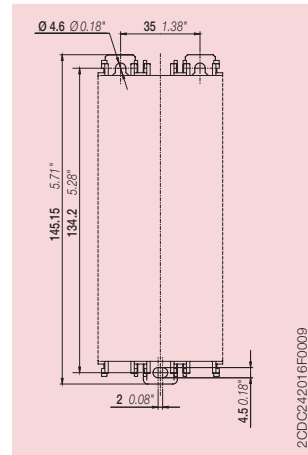

MS165 drilling plan

## Technical data IEC/EN

Data at  $T_A = 40\text{ °C}$  and at rated values, if nothing else indicated

### Main circuit

	<b>1L1-3L2-5L3</b> <b>2T1-4T2-6T3</b>
Rated operational voltage $U_e$	690 V AC / 250 V DC (3 poles in series)
Setting range - thermal overload protection	see table "Order data" on page 1
Rated operational current $I_n$	see table below
Rated operational current DC-5 $I_n$ (250 V DC) 3 poles in series	see "Rated operational current $I_n$ "
Rated instantaneous short-circuit current setting $I_i$	see table below
Rated service short-circuit breaking capacity $I_{cs}$	see table "Short-circuit breaking capacity and back-up fuses" see table on page 6
Rated ultimate short-circuit breaking capacity $I_{cu}$	100 kA
Rated service short-circuit breaking capacity DC $I_{cs}$ (250 V DC) 3 poles in series	see table "Order data" on page 1
Trip class	DC, 50/60 Hz
Rated frequency	DC, 15 ... 415 Hz
Operated frequency	3
Number of poles	see table "Resistance and power loss per pole"
Resistance per pole	see table on page 3
Power loss per pole	

<b>Isolation data</b>	
Rated impulse withstand voltage $U_{imp}$	8 kV
Rated insulation voltage $U_i$	1000 V
Pollution degree	3

<b>Electrical connection</b>		
	stranded	1/2 x 1 ... 50 mm <sup>2</sup>
	flexible with ferrule	1/2 x 1 ... 35 mm <sup>2</sup>
	flexible with ferrule insulated	1/2 x 1 ... 35 mm <sup>2</sup>
	flexible without ferrule	1/2 x 1 ... 35 mm <sup>2</sup>
Stripping length		16 mm
Tightening torque		4 Nm
Recommended screw driver		Pozidriv 2

Type	Rated instantaneous short-circuit current setting $I_i$	Rated operational current $I_n$
	A	A
MS165-16	240	16
MS165-20	300	20
MS165-25	375	25
MS165-32	480	32
MS165-42	630	42
MS165-54	810	54
MS165-65	975	65

## General data

Mechanical durability		50000
Electrical durability		25000
Duty time		100 %
Operating frequency without early tripping		up to 15 operations/h or 60 operations/h with 40 % duty ratio, if the motor breaking current $6 \times I_n$ and the motor starting time does not exceed 1 s
Dimensions (W x H x D)		see drawing "Dimensions" on page 3
Weight		see table "Order data" on page 1
Mounting on DIN rail		TH35-15 (35 x 15 mm Mounting Rail) acc. to IEC 60715 TH35-7.5 (35 x 7.5 mm Mounting Rail) acc. to IEC 60715
Mounting position		position 1-6 (optional for single mounting)
Group mounting		on request
Minimum distance to other units same type	horizontal	0 mm
	vertical	150 mm
Minimum distance to electrical conductive board	horizontal, up to 400 V	0 mm
	horizontal, up to 690 V	> 1.5 mm
	vertical	75 mm
Degree of protection	housing / main circuit terminals	IP20 / IP10
Utilization category		A
Maximum operating altitude permissible		2000 m
Maximum operating frequency		50 cycles/h
Recommended screw for mounting plate		M4
Screw torque for mounting plate		2 Nm

## Electromagnetic compatibility

Electromagnetic compatibility		not applicable
-------------------------------	--	----------------

## Environmental data

Ambient air temperature		
Operation	open - compensated	-25 ... +60 °C
	open	-25 ... +60 °C
Storage		-50 ... +80 °C
Ambient air temperature compensation		acc. to IEC/EN 60947-4-1
Resistance to vibrations acc. to IEC 60068-2-6		5g / 3 ... 150 Hz
Resistance to shock acc. to IEC 60068-2-27		25g / 11 ms

## Standards / directives

Standards		IEC/EN 60947-1 IEC/EN 60947-2 IEC/EN 60947-4-1 UL 60947-1 UL 60947-4-1 CSA-C22.2 No. 60947-1 CSA-C22.2 No. 60947-4-1
Low Voltage Directive		2014/35/EU
RoHS Directive		2011/65/EC

## Short-circuit breaking capacity and back-up fuses

$I_{cs}$  Rated service short-circuit breaking capacity

$I_{cu}$  Rated ultimate short-circuit breaking capacity

- No back-up fuse required, because short-circuit proof up to 100 kA

Type	230 V AC			400 V AC			440 V AC			500 V AC		
	$I_{cs}$ kA	$I_{cu}$ kA	gG A	$I_{cs}$ kA	$I_{cu}$ kA	gG A	$I_{cs}$ kA	$I_{cu}$ kA	gG A	$I_{cs}$ kA	$I_{cu}$ kA	gG A
MS165-16	100	100	-	100	100	-	75	75	125*	40	40	125*
MS165-20	100	100	-	100	100	-	75	75	125*	40	40	125*
MS165-25	100	100	-	100	100	-	50	50	125*	30	30	125*
MS165-32	100	100	-	100	100	-	50	50	125*	30	30	125*
MS165-42	50	50	125*	50	50	125*	50	50	125*	30	30	125*
MS165-54	30	50	125*	30	50	125*	30	45	125*	20	20	125*
MS165-65	30	50	125*	30	50	125*	30	45	125*	20	20	125*

Type	690 V AC			250 V DC **		
	$I_{cs}$ kA	$I_{cu}$ kA	gG A	$I_{cs}$ kA	$I_{cu}$ kA	gG A
MS165-16	10	10	63*	100	100	-
MS165-20	10	10	63*	100	100	-
MS165-25	10	10	80*	100	100	-
MS165-32	10	10	100*	100	100	-
MS165-42	10	10	100*	100	100	-
MS165-54	5	8	100*	100	100	-
MS165-65	5	8	100*	100	100	-

\*) Rated back-up fuse for short-circuit up to 100 kA

\*\*) 3 poles in series

## Technical data UL/CSA

### Main circuit

Maximum operational voltage		600 V
Motor ratings	Horsepower	see table below
	Full Load Amps (FLA)	see table below
	Locked Rotor Amps (LRA)	see table below

<b>Electrical connection</b>		<b>MS165</b>
Connecting capacity	stranded	1/2 x AWG 16 ... 0
	flexible without ferrule	1/2 x AWG 16 ... 0
Stripping length		16 mm
Tightening torque		35 lb-In
Recommended screw driver		Pozidriv 2
Recommended screw for mounting plate		M4
Screw torque for mounting plate		18 lb-In

### Motor ratings, single-phase

Type	120 V AC			220 ... 240 V AC		
	hp	FLA	LRA	hp	FLA	LRA
MS165-16	1	16	96	2	12	72
MS165-20	1 1/2	20	120	3	17	102
MS165-25	2	24	144	3	17	102
MS165-32	2	24	144	5	28	168
MS165-42	3	34	204	7 1/2	40	240
MS165-54	3	34	204	10	50	300
MS165-65	5	56	336	10	50	300

### Motor ratings, three-phase

Type	200 V AC			208 V AC			220 ... 240 V AC			440 ... 480 V AC			550 ... 600 V AC		
	hp	FLA	LRA	hp	FLA	LRA	hp	FLA	LRA	hp	FLA	LRA	hp	FLA	LRA
MS165-16	3	11	73.6	3	10.6	71	5	15.2	92	10	14	81	10	11	64.8
MS165-20	5	17.5	105.8	5	16.7	102	5	15.2	92	10	14	81	15	17	93
MS165-25	5	17.5	105.8	7 1/2	24.2	140	7 1/2	22	127	15	21	116	20	22	116
MS165-32	7 1/2	25.3	146	10	30.8	179	10	28	162	20	27	145	30	32	174
MS165-42	10	32.2	186.3	10	30.8	179	15	42	232	30	40	218	40	41	232
MS165-54	15	48.3	267	15	46.2	257	20	54	290	40	52	290	50	52	290
MS165-65	20	62.1	334	20	59.4	321	20	54	290	50	65	363	60	62	348

hp Horsepower  
 FLA Full Load Amps  
 LRA Locked Rotor Amps

Note: Manual motor starters should always be selected so that the actual motor current is within the setting range; see ordering detail pages. Horsepower (hp) ratings are for reference only.

Maximum short-circuit current ratings

Type	Manual Motor Controllers								Manual self-protected Combination Motor Controllers (Type E)	
	Branch circuit protection, max. size per NEC/CEC <sup>1)</sup>		for motor disconnect		for group installations		for tap conductor protection in group installations			
	Fuses	Circuit breaker	480 V	600 V	480 V	600 V	480 V	600 V	480Y / 277 V	600Y / 347 V
	A	A	kA	kA	kA	kA	kA	kA	kA	kA
MS165-16	Any listed fuses. Size per NEC/CEC	Any listed UL489 / CSA C22.2 No.5 circuit breaker. Size per NEC/CEC	65	30	65	30	65	30	65	30
MS165-20			65	30	65	30	65	30	65	30
MS165-25			65	30	65	30	65	30	65	30
MS165-32			65	30	65	30	65	30	65	30
MS165-42			65	30	65	30	65	30	65	30
MS165-54			65	30	65	30	65	30	65	30
MS165-65			65	30	65	30	65	30	65	30

<sup>1)</sup> NEC: NFPA@70 National Electrical Code®; CEC: CSA C22.1 Canadian Electrical Code.

Maximum short-circuit current ratings – MS165 with AF contactors

Type	Manual self-protected Combination Motor Controllers (Type F) Coordination type 1					Manual self-protected Combination Motor Controllers (Type F) Coordination type 2				
	Minimum contactor size	480Y / 277 V	Minimum contactor size	600Y / 347 V	Minimum contactor size	480Y / 277 V	Minimum contactor size	600Y / 347 V		
		kA		kA		kA		kA		
MS165-16	AF09 ... AF38	65	AF09 ... AF38	50	AF26 ... AF38	65	AF09 ... AF38	30		
MS165-20	AF26 ... AF38	65	AF26 ... AF38	50	AF26 ... AF38	65	AF09 ... AF38	30		
MS165-25	AF26 ... AF38	65	AF26 ... AF38	50	AF26 ... AF38	65	AF40 ... AF65	30		
MS165-32	AF26 ... AF38	65	AF26 ... AF38	50	AF26 ... AF38	65	AF40 ... AF65	30		
MS165-42	AF40 ... AF65	65	AF40 ... AF65	30	AF40 ... AF65	65	AF40 ... AF65	30		
MS165-54	AF40 ... AF65	65	AF40 ... AF65	30	AF40 ... AF65	65	AF40 ... AF65	30		
MS165-65	AF40 ... AF65	65	AF40 ... AF65	30	AF40 ... AF65	65	AF40 ... AF65	30		



# Contact us

## **ABB STOTZ-KONTAKT GmbH**

Eppelheimer Straße 82  
69123 Heidelberg, Germany  
Phone: +49 (0) 6221 7 01-0  
Fax: +49 (0) 6221 7 01-13 25  
E-Mail: [info.desto@de.abb.com](mailto:info.desto@de.abb.com)

You can find the address of your  
local sales organization on the  
ABB home page  
<http://www.abb.com/contacts>  
-> Low Voltage Products and Systems

### **Note:**

We reserve the right to make technical changes or modify the contents of this document without prior notice. With regard to purchase orders, the agreed particulars shall prevail. ABB AG does not accept any responsibility whatsoever for potential errors or possible lack of information in this document.

We reserve all rights in this document and in the subject matter and illustrations contained therein. Any reproduction, disclosure to third parties or utilization of its contents – in whole or in parts – is forbidden without prior written consent of ABB AG.

Copyright© 2018 ABB  
All rights reserved