

---

CATALOG

# EasyLine XLP

## Fuse Switch Disconnecter 1-2-3-4 poles





---

# Contents

<b>004–005</b>	<b>Introduction</b> EasyLine XLP	<b>014–014</b>	<b>Ordering information</b> XLP 3-pole
<b>006–007</b>	<b>Introduction</b> Applications	<b>015–015</b>	<b>Ordering information</b> XLP 1-, 2- and 4-pole
<b>008–008</b>	<b>Introduction</b> Product overview	<b>016–018</b>	<b>Ordering information</b> Busbar system
<b>009–009</b>	<b>Electronic Fuse</b> <b>Monitoring</b> 3-pole	<b>019–021</b>	<b>Ordering information</b> Accessories
<b>010–010</b>	<b>40 mm Busbar System</b> XLP00 and XLP1	<b>022–023</b>	<b>Ordering information</b> Accessories for busbar system
<b>011–011</b>	<b>60 mm Busbar System</b> XLP00, XLP1, XLP2 , XLP3 and XLPD0	<b>024–025</b>	<b>Ordering information</b> Accessories for XLPD0
<b>012–013</b>	<b>Cable clamps &amp; bolts</b> Accessories	<b>026–028</b>	<b>Technical data</b>
		<b>030–038</b>	<b>Dimensional drawings</b>

# Introduction

## EasyLine XLP

The EasyLine family consists of 1, 2, 3 and 4 pole solutions. All variants of poles are available in different fuse sizes/rated operational currents from 100A up to 630A: NH00/160A, NH1/250A, NH2/400A and NH3/630A



### Safety and protection

- The EasyLine fuse switch-disconnector fulfil the highest requirements for modern fuse switch with a total safety concept. The fuse switches are tested according to the EN 60947-3 standard with more stringent requirements for isolation, making, performance and safety.
- EasyLine range of fuse switch-disconnectors ensures high protection and reliable operation in a wide variety of applications, such as critical power applications, distribution boards, switchboards or capacitor banks.
- The whole EasyLine range got a sturdy, uniform design that is operator friendly. The degree of protection from the front is IP30 in closed position and IP20 in open position. <sup>1)</sup>
- Quick-make operation device
- Voltage measuring from the front



### Easy to install

- A wide range of cable terminals and Snap-On accessories make the installation easy and fast.
- All the XLP cable terminals can be delivered with integrated bolts for cable lugs or with integrated bridge clamps (BC) for easy direct cable connection.
- Compact, add-on Electronic Fuse Monitoring (EFM)
- Replacement compatible to similar types in the market



### Affordable Range

- Fuse switch-disconnectors combined with fuse links can withstand high fault level and a fault currents. In addition devices are available at economical prices.



XLP 1,2,3 and 4-pole solutions



# Introduction

## Applications

### Applications:

- UPS for the power supply of computer/servers, storage devices, communication network systems, industry control systems and others
  - suggested size: 1-, 2- and 3-pole
- Telecommunications power supplies
  - suggested size: 1- and 2-pole
- Metering or lighting module applications
  - suggested size: 1-, 2- and 3-pole
- Capacitor banks
  - suggested size: 3-pole
- Switchboards
  - suggested size: XLP 3-Pole and XLPO0 devices
- General fuse protection for power supply networks with switching neutral
  - suggested size: 4-pole XLP
- Secondary power generators from public networks
  - suggested size: 4-pole XLP

—  
UPS for the power supply of computer/servers



—  
Telecommunications power supplies



—  
Metering or lighting module applications



—  
Switchboards



—  
Capacitor banks



—  
General fuse  
protection for power  
supply networks with  
switching neutral



—  
Secondary power  
generators from  
public networks



# Introduction

## Product overview



	XLP 1-pole	XLP 2-pole	XLP000 Compact design for NH00C DIN-fuses (width = 21 mm)	XLP00, XLP1, XLP2 and XLP3	XLP 4-pole
Rated operational voltage	220VDC / 500 - 690VAC	220 - 440VDC / 500 - 690VAC	400 - 690VAC	400 - 800VAC	550VAC
Rated operational current	160 - 630A	160 - 630A	50 - 100A	125 - 630A	160 - 630A
<b>Available accessories</b>					
Micro auxillary switches	● (1 or 2 pcs per pole)	● (1 or 2 pcs per pole)	● (1 or 2 pcs)	● (1 or 2 pcs)	● (1 or 2 pcs)
Auxilliary switches, 1 NO or 1 NC acc. to IEC 60947-5-1				●	●
Cable shroud	● (Single cable shroud per phase)	● (Single cable shroud per phase)	● Integrated (IP20)	●	●
Cable clamps	●	●	● Integrated (for 1,5 - 35 mm <sup>2</sup> cables)	●	●
Front frames	●	●	● (for 1 – 3 devices)	●	●
Padlocking	●	●		●	●
Sealing facility	●	●	●	●	●
Snap-on for DIN rail mounting			●	●	
Electronic fuse monitoring (EFM)				●	
Busbar adapter for 40 mm				● (only XLP00)	
Busbar adapter for 60 mm				● (only XLP00 and XLP1)	

DIN-type HRC-fuse links, gG- and aM- types can be used with EasyLine XLP00,XLP1, XLP2 and XLP3.  
For more information refer to the catalog Fusegear, code 1SCC317001C0201





# Electronic Fuse Monitoring

## 3-pole

The Electronic Fuse Monitoring (EFM) is a fuse blown indication device. The EFM unit has an integrated potential free relay (1NO, 1NC) for remote signal/alarm. It will be automatically reset after the blown fuse has been replaced and the green LED turns on again.

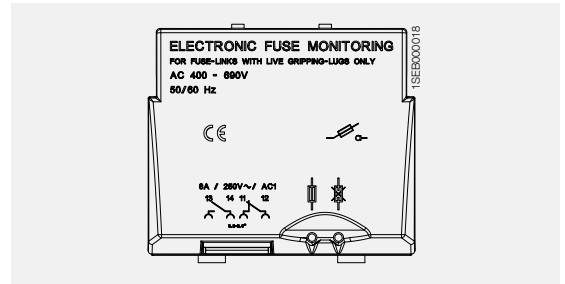

The matrix below show all possible cases of indication

Fuse status	Relay contacts		NO contact 13, 14		NO contact 11, 12	
	Green	Red	Open	Closed	Open	Closed
<b>1. Closed</b>						
Fuse OK	●	●	X			X
Fuses BLOWN	●	●		X	X	
<b>2. Open</b>						
Fuse OK	●	●	X			X
Fuses BLOWN	●	●	X			X

Power supply to the EFM unit from phase L2 and L3

The fuse monitor is connected to the gripping lugs of the fuses.

NOTE :

- NH fuses with insulated gripping lugs can not be used.
- The EFM unit requires that the supply side of the XLP should be on top of the switch.



### Technical data

Input voltage limits	
Application AC voltage $U_e$	280-880V
DC 110: Rated DC voltage $U_e$	40-140V
DC 500: Rated DC voltage $U_e$	135-550V
Power consumption	2W
Functional characteristics	
Operating time $t_e$	$\leq 4$ s
Measuring accuracy	$\pm 5\%$
Signaling output terminals (multiplug)	
Normally open	Terminals 11 - 12
Normally closed	Terminals 12 - 13
Rated load, inductive	2A at 24 VDC Utilization category DC-1
Rated load, resistive	4A at 24 VDC Utilization category DC-13
Wiring capacity [mm <sup>2</sup> ]	Stranded / solid: 0.08 - 0.5/
	0.08 - 0.75
	Stranded with ferrule, no plastic sleeve: 0.25 - 0.34
	Stranded with twin ferrule, plastic sleeve: 0.5
EFM unit's dielectric properties (IEC 60947-1)	
Rated impulse withstand voltage ( $U_{imp}$ )	6.0kV
All poles connected together/Earth	1.89 kV/1 min 50 Hz
All poles connected together/Aux. contacts	1.89 kV/1 min 50 Hz
Insulation resistance	1 M $\Omega$ , 500 VDC

## 40 mm Busbar System

### XLP00 and XLP1

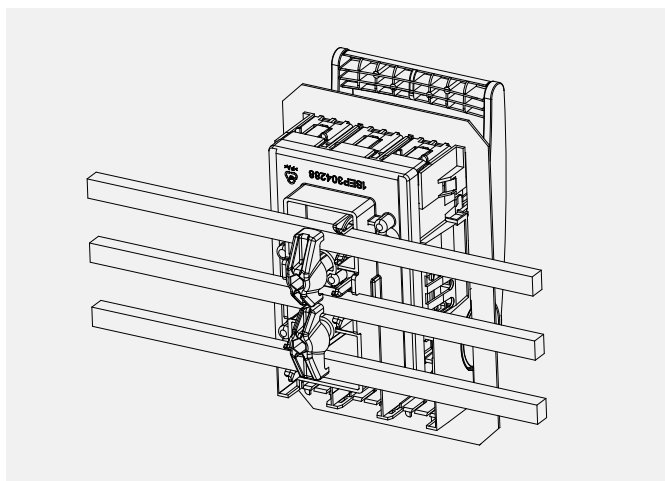

#### 40 mm busbar system for XLP00

- Cu 12 x 5 mm or 12 x 10 mm.
- Adapter 95 mm depth to busbars, cable connection below: A 40/95

#### 40 mm Busbar system for XLP00 and XLP1 ABB Striebel & John switchboards

- Specially designed for ABB Striebel & John Busbar system 250A and 360A.
- Cu 12x5 or 12x10 mm.
- XLP00, adapter 75 mm depth to busbars, cable connection below: A 40/75
- XLP00, adapter 120 mm depth to busbars, cable connection below: A 40/120
- XLP1, adapter 120 mm depth to busbars, cable connection above: A 40/120



# 60 mm Busbar System

XLP00, XLP1, XLP2 , XLP3 and XLPD0

## 60 mm busbar system

	Dimensions of the busbar
XLP00, XLP1, XLP2 and XLP3	5 or 10 mm (thickness) x 10-30 mm (width)
XLPD0_	5 or 10 mm (thickness) x 12-30 mm (width)

### XLP

XLP00 and XLP1 adapters include 3 pieces of distance shoes for 5 mm busbars.

The XLP adapters are available for cable connection above (A) or cable connection below (B):

- XLP00, adapters for 60 mm depth to busbars
- XLP1, adapters for 85 mm depth to busbars
- XLP2 and XLP3 adapters for 120 mm depth to busbars

### XLPD0

XLPD0 devices are fast and easy to install to the busbar without tools.

XLPD0 Bus-mounted fuse switch can be pad-locked in OFF position (O) and sealed in ON position (I). The devices have to be equipped with D0 gauge rings. Together with reducer also suitable for fuse links D01. The use of 9 mm side module is recommended for continuous load more than 35A. Use of D02 fuse links with silver plated caps is recommended.

XLPD0 Fuse bases have comprehensive shock protection including a strip cover.

Fuse bases are available for neozed (D02) and diized (DII, DIII) fuses. D02 bus-mounting fuse bases are also suitable for D01 bus-mounting fuse bases thanks to special holding springs and special ferrule gauge pieces. From a permanent load of 35A, the 36 mm-wide version is recommended due to the heat produced.

XLPD0 bus-mounted fuse holder for cylindrical fuses 10x38. Fuse holder is UL recognized.



XLP



Bus mounted  
fuse switch

















XLPD0 fuse bases







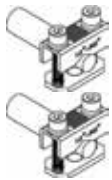

XLPD0 bus-mounted fuse  
holder for cylindrical fuses

# Cable clamps & bolts

## Accessories

Type of clamp/bolt	Busbars height/weight (mm <sup>2</sup> )	Conductor cross section min-max			Torque (Nm) <sup>1)</sup>	Order code
		Conductor flexible (mm <sup>2</sup> )	Rm/Sm (mm <sup>2</sup> )	Re/Se (mm <sup>2</sup> )		
<b>XLP000</b>						
 Cage clamp (6pcs x CC)		1,5 - 25	1,5 - 35	1,5 - 35	3,2	Incl. in the switch
<b>XLP00</b>						
 Bridge clamp (3pcs x BC)		1,5 - 35	1,5 - 50	1,5 - 50	3,5	1SEP407733R0001
 Triple clamp (3pcs x TC)		1,0 - 10	1,0 - 10	1,0 - 10	3,5	1SEP407787R0001
 Single prism clamp (3pcs x SPC)		1,5 - 16	1,5 - 16	1,5 - 16		1SEP407732R0001
		25 - 50	25 - 70	25 - 70	3,5	
 Feeding clamp (3pcs x FC) for XLP00 - 6BC		25 - 70	25 - 95	25 - 95	10	1SEP407811R0001
 Bolt 3pcs x M8x16 DIN933	20 x 4					
 Bolt 3pcs x M8x16 DIN933 for Cable lug DIN46234		10 - 95	10 - 95	10 - 95		NHP 400940R0006
 Bolt 3pcs x M8x16 DIN933 for Cable lug DIN46235		16 - 70	16 - 70	16 - 70	10	
<b>XLP1</b>						
 Bridge clamp (3pcs x BC)	19 x 10	16 - 70	16 - 95	16 - 95	10	1SEP407733R0002
 Single prism clamp (3pcs x SPC)		16 - 70	16 - 95	16 - 95		1SEP407732R0002
		95 - 150	95 - 150 <sup>2)</sup>	95 - 150	10	
 Double prism clamp (3pcs x DPC)		2x70 - 2x95	2x70 - 2x150	2x70 - 2x150	10	NHP 403631R0002
 Bolt 3pcs x M10x20 DIN933	40 x 10					
 Bolt 3pcs x M10x20 DIN933 for Cable lug DIN46234		10 - 240	10 - 240	10 - 240		NHP 403625R0001
 Bolt 3pcs x M10x20 DIN933 for Cable lug DIN46235		16 - 240	16 - 240	16 - 240	16	

Type of clamp/bolt	Busbars height/weight (mm <sup>2</sup> )	Conductor cross section min-max			Torque (Nm) <sup>1)</sup>	Order code
		Conductor flexible (mm <sup>2</sup> )	Rm/Sm (mm <sup>2</sup> )	Re/Se (mm <sup>2</sup> )		
XLP2 and 3		16-70 (M8x25) 300 (M8x40)	16-50 (M8x25) 185-300 (M8x40)	16-50 (M8x25) 185-300 (M8x40)		
 Bridge clamp (3pcs x BC)	14 x 26	70 - 240	50 - 185	50 - 185	14	1SEP407953R0001
 Single prism clamp (3pcs x SPC)		95 - 240	70 - 240	95 - 240		1SEP407954R0001
 Double Prism clamp (3pcs x DPC)		25 - 95	35 - 70	50 - 70	14	
 Double Prism clamp (3pcs x DPC)		2x35 - 2x120	2x35 - 2x150	2x35 - 2x50 2x50 - 2x185	22	1SEP407956R0001
 Bolt 3pcs x M12x30 DIN933	50 x 12					NHP 403626R0001
 Bolt 3pcs x M12x30 DIN933 for Cable lug DIN46234		10 - 240	10 - 240	10 - 240		
 Bolt 3pcs x M12x30 DIN933 for Cable lug DIN46235		16 - 300	16 - 300	16 - 300	25	

1) For correct Torque (Nm) values, study the installation description delivered with the devices

2) The Sm (sector shaped stranded) 150 mm<sup>2</sup> have to be round formed before inserted in the Prism clamp

Type tested according to standard: EN IEC 60947-1 and DIN VDE 0295.

**Explanations:**

- Flexible: Multi stranded
- Re: Round solid
- Se: Sector shaped solid
- Rm: Round stranded
- Sm: Sector shaped stranded

# Ordering information

## XLP 3-pole

Rated operational current [A]	Fuse size	Number of poles	Type	Description	Order code	Weight (Kg)
<b>XLP000</b>						
100A	NH000/NH00C	3	XLP000-6CC	incl. 6 Cage Clamps	1SEP201428R0001	0,46
100A	NH000/NH00C	3	XLP000-6CC in carton	incl. 6 Cage Clamps in carton	1SEP201428R0002	0,5
<b>XLP00</b>						
160A	NH000/NH00	3	XLP00	without clamps or bolts	1SEP101890R0001	0,55
160A	NH000/NH00	3	XLP00-6BC	incl. 6 Bridge Clamps	1SEP101890R0002	0,63
160A	NH000/NH00	3	XLP00-6M8	incl. 6 x M8x16 mm bolts	1SEP101890R0004	0,63
160A	NH000/NH00	3	XLP00-6BC-3M8	incl. 6 Bridge Clamps and 3 x M8x16 mm bolts	1SEP101890R8002	0,65
160A	NH000/NH00	3	XLP00-EFM-6BC	incl. Electronic Fuse Monitoring and 6 Bridge Clamps	1SEP101890R0012	0,68
<b>XLP1</b>						
250A	NH1	3	XLP1	without clamps or bolts	1SEP101891R0001	1,6
250A	NH1	3	XLP1-6BC	incl. 6 Bridge Clamps	1SEP101891R0002	1,8
250A	NH1	3	XLP1-6M10	incl. 6 x M10 bolts	1SEP101891R0004	1,8
250A	NH1	3	XLP1-EFM-6BC	incl. Electronic Fuse Monitoring and 6 Bridge Clamps	1SEP101891R0012	2
<b>XLP2</b>						
400A	NH2	3	XLP2	without clamps or bolts	1SEP101892R0001	2,50
400A	NH2	3	XLP2-6BC	incl. 6 Bridge Clamps	1SEP101892R0002	3
400A	NH2	3	XLP2-EFM-6BC	incl. Electronic Fuse Monitoring and 6 Bridge Clamps	1SEP101892R0012	3,2
<b>XLP3</b>						
630A	NH3	3	XLP3	without clamps or bolts	1SEP101975R0001	3,7
630A	NH3	3	XLP3-6BC	incl. 6 Bridge Clamps	1SEP101975R0002	4,25
630A	NH3	3	XLP3-EFM-6BC	incl. Electronic Fuse Monitoring and 6 Bridge Clamps	1SEP101975R0012	4,4



XLP000



XLP00



XLP1



XLP2



XLP3

# Ordering information

## XLP 1-, 2- and 4-pole

Rated operational current [A]	Fuse size	Number of poles	Type	Description	Order code	Weight (Kg)
<b>1-pole</b>						
160A	NH000/NH00	1	XLP00-1P	without clamps or bolts	1SEP600113R0001	0,24
160A	NH000/NH00	1	XLP00-1P-2BC	incl. 2 Bridge Clamps	1SEP600113R0002	0,28
160A	NH000/NH00	1	XLP00-1P-2M8	incl. 2 x M8 bolts	1SEP600113R0003	0,26
250A	NH1	1	XLP1-1P	without clamps or bolts	1SEP600116R0001	0,7
250A	NH1	1	XLP1-1P-2BC	incl. 2 x Bridge Clamps	1SEP600116R0002	0,82
250A	NH1	1	XLP1-1P-M10	incl. M10 bolts	1SEP600116R0003	0,76
400A	NH2	1	XLP2-1P	without clamps or bolts	1SEP600122R0001	1,06
400A	NH2	1	XLP2-1P-2BC	incl. 2 x Bridge Clamps	1SEP600122R0002	1,25
630A	NH3	1	XLP3-1P	without clamps or bolts	1SEP600126R0001	1,87
630A	NH3	1	XLP3-1P-2BC	incl. 2 x Bridge Clamps	1SEP600126R0002	2,2
<b>2-pole</b>						
160A	NH000/NH00	2	XLP00-2P	without clamps or bolts	1SEP600114R0001	0,53
160A	NH000/NH00	2	XLP00-2P-4BC	incl. 4 x Bridge Clamps	1SEP600114R0002	0,61
160A	NH000/NH00	2	XLP00-2P-4M8	incl. 4 x M8 bolts	1SEP600114R0003	0,57
250A	NH1	2	XLP1-2P	without clamps or bolts	1SEP600117R0001	1,63
250A	NH1	2	XLP1-2P-4BC	incl. 4 x Bridge Clamps	1SEP600117R0002	1,87
250A	NH1	2	XLP1-2P-4M10	incl. 4 x M10 x 20 bolts	1SEP600117R0003	1,75
400A	NH2	2	XLP2-2P	without clamps or bolts	1SEP600123R0001	2,32
400A	NH2	2	XLP2-2P-4BC	incl. 4 x Bridge Clamps	1SEP600123R0002	2,7
630A	NH3	2	XLP3-2P	without clamps or bolts	1SEP600127R0001	3,95
630A	NH3	2	XLP3-2P-4BC	incl. 4 x Bridge Clamps	1SEP600127R0002	4,5
<b>4-pole</b>						
160A	NH000/NH00	4	XLP00-4P	without clamps or bolts	1SEP600115R0001	0,83
160A	NH000/NH00	4	XLP00-4P-8BC	incl. 8 x Bridge Clamps	1SEP600115R0002	0,99
160A	NH000/NH00	4	XLP00-4P-8M8	incl. 8 x M8 bolts	1SEP600115R0003	0,91
250A	NH1	4	XLP1-4P	without clamps or bolts	1SEP600119R0001	2,5
250A	NH1	4	XLP1-4P-8BC	incl. 8 x Bridge Clamps	1SEP600119R0002	2,98
250A	NH1	4	XLP1-4P-8M10	incl. 8 x M10 x 20 bolts	1SEP600119R0003	2,74
400A	NH2	4	XLP2-4P	without clamps or bolts	1SEP600124R0001	3,87
400A	NH2	4	XLP2-4P-8BC	incl. 8 x Bridge Clamps	1SEP600124R0002	4,5
630A	NH3	4	XLP3-4P	without clamps or bolts	1SEP600128R0001	6,47
630A	NH3	4	XLP3-4P-8BC	incl. 8 x Bridge Clamps	1SEP600128R0002	7,5



1-pole



2-pole



4-pole

# Ordering information

## Busbar system

### 40 mm and 50 mm Busbar System

Rated operational current [A]	Fuse size	Number of poles	Type	Description	Order code	Weight (Kg)
<b>XLP00</b>						
160A	NH000/ NH00	3	XLP00-A40/95-B-3BC-below	incl. A40/95 adapter and 3 Bridge Clamps, cable below	1SEP101889R0002	1,1
160A	NH000/ NH00	3	XLP00-A40/75-B-3BC-below	incl. A40/75 adapter and 3 Bridge Clamps, cable below	1SEP101898R0002	1
160A	NH000/ NH00	3	XLP00-A40/75-B-3M8-below	incl. A40/75 adapter and 3 x M8 bolts, cable below	1SEP101898R0004	1
160A	NH000/ NH00	3	XLP00-A40/120-B-3BC-below	incl. A40/120 adapter and 3 Bridge Clamps, cable below	1SEP101899R0002	1,2
160A	NH000/ NH00	3	XLP00-A40/120-B-3M8-below	incl. A40/120 adapter and 3 x M8x16 mm bolts, cable below	1SEP101899R0004	1,2
160A	NH000/ NH00	3	XLP00-MNS adapter-3BC	incl. MNS adapter and 3 Bridge Clamps	1SEP101890R0402	0,88
160A	NH000/ NH00	3	XLP00-MNS adapter-EFM-3BC	incl. MNS adapter, EFM and 3 Bridge Clamps	1SEP101890R0412	1,1
<b>XLP1</b>						
250A	NH1	3	XLP1-A40/120-A-3BC-above	incl. A40/120 adapter and 3 Bridge Clamps, cable above	1SEP101912R0002	2,8
250A	NH1	3	XLP1-A40/120-A-3M10-above	incl. A40/120 adapter and 3xM10x20 mm bolts, cable above	1SEP101912R0004	2,75



XLP00-A40



XLP00-MNS adapter



XLP1-A40/120-A



---

**60 mm Busbar System**

Rated operational current [A]	Fuse size	Number of poles	Type	Description	Order code	Weight (Kg)
<b>XLP00</b>						
160A	NH000/ NH00	3	XLP00-A60/60-B-3BC-below	incl. A60/60 adapter and 3 Bridge Clamps, cable below	1SEP101916R0001	0,95
160A	NH000/ NH00	3	XLP00-A60/60-B-below	incl. A60/60 adapter and cable below, without clamps or bolts	1SEP101916R0002	0,95
160A	NH000/ NH00	3	XLP00-A60/60-A-3BC-above	incl. A60/60 adapter and 3 Bridge Clamps, cable above	1SEP101917R0001	0,95
<b>XLP1</b>						
250A	NH1	3	XLP1-A60/85-B-3BC-below	incl. A60/85 adapter and 3 Bridge Clamps, cable below	1SEP101918R0001	2,47
250A	NH1	3	XLP1-A60/85-A-3BC-above	incl. A60/85 adapter and 3 Bridge Clamps, cable above	1SEP101919R0001	2,47
<b>XLP2</b>						
400A	NH2	3	XLP2-A60/120-A-above	incl. A60/120 adapter, cable above without clamps or bolts	1SEP102285R0001	4,9
400A	NH2	3	XLP2-A60/120-B-below	incl. A60/120 adapter, cable below without clamps or bolts	1SEP102286R0001	4,9
<b>XLP3</b>						
630A	NH3	3	XLP3-A60/120-A-above	incl. A60/120 adapter, cable above without clamps or bolts	1SEP102287R0001	7,4
630A	NH3	3	XLP3-A60/120-B-below	incl. A60/120 adapter, cable below without clamps or bolts	1SEP102288R0001	7,4



XLP00-A60/60



XLP1-A60/85



XLP2-A60/120



XLP3-A60/120-A-above



XLP3-A60/120-B-below

# Ordering information

## Busbar system

### 60 mm Busbar System

Rated operational current [A]	Fuse size	Number of poles	Type	Description	Order code	Weight (Kg)	Quantity (pcs/package)
<b>XLPD0</b>							
63A	D01, D02	3	XLPD0-FS-E18-3P <sup>1)</sup>	Bus-mounted switch disconnecter fuse, E18	1SEP622349R0001	0,3	1/1
63A	D02	3	XLPD0-FB-E18/27-3P	Bus-mounted fuse base, E18, 27 mm	1SEP622350R0001	0,1	8/1
63A	D02	3	XLPD0-FB-E18/36-3P	Bus-mounted fuse base, E18, 36 mm	1SEP622351R0001	0,2	6/1
25A	DII	3	XLPD0-FB-E27/42-3P	Bus-mounted fuse base, E27, 42 mm	1SEP622352R0001	0,3	8/1
63A	DIII	3	XLPD0-FB-E33/57-3P	Bus-mounted fuse base, E33, 57 mm	1SEP622345R0001	0,4	6/1
32A	10x38	3	XLPD0-FS-1038-3P	Bus-mounted fuse holder for cylindrical fuses 10x38	1SEP622346R0001	0,2	4/1
-	-	-	SM-XLPD0-FS	Side module 9 mm	1SEP622389R0001	0,1	5/1

1) The use of SM-XLPD0-FS side module 9 mm is recommended for continuous loads above 35A.



XLPD0-FS-E18-3P



XLPD0-FB-E18/27-3P



XLPD0-FB-E18/36-3P



XLPD0-FB-E27/42-3P



XLPD0-FB-E33/57-3P



XLPD0-FS-1038-3P



SM-XLPD0-FS

# Ordering information

## Accessories

### Common accessories for XLP

Image n.	Type	Order code	Weight (Kg)
01	Micro auxiliary switch (not for XLP000)	1SEP407742R0001	0,01
02	Auxiliary switch NC (Red)	1SEP407742R0002	0,02
	Auxiliary switch NO (Green)	1SEP407742R0003	0,02
03	Padlock device	1SEP407786R0001	0,005

### Accessories XLP000 - 3-pole

Image n.	Type	Order code	Weight (Kg)
	XLP000 Micro auxiliary switch	1SEP408738R0001	0,01
04	XLP000 DIN rail snap on kit - Qty. 1 pc	1SEP407740R0001	0,006
04	XLP000 DIN rail snap on kit - Qty. 10 pc	1SEP407740R0010	0,6
05	XLP000 Frontframe for 1 XLP000	1SEP407741R0001	0,02
05	XLP000 Frontframe for 2 XLP000	1SEP407741R0002	0,025
05	XLP000 Frontframe for 3 XLP000	1SEP407741R0003	0,03



01



02



03



04



05

# Ordering information

## Accessories

### Accessories XLP00 - 3-pole

Image n.	Type	Order code	Weight (Kg)
	XLP00 A60/60 Adapter above, for 60 mm busbar distance, 5 or 10 mm, cable above	1SEP101910R0001	0,38
	XLP00 A60/60 Adapter below, for 60 mm busbar distance, 5 or 10 mm, cable below	1SEP101915R0001	0,38
	XLP00 A40/75 Adapter above/below, for 40 mm busbarsystem Striebel & John, cable above or below	1SEP101909R0001	
	XLP00 A40/120 Adapter above/below, for 40 mm busbarsystem Striebel & John, cable above or below	1SEP101909R0002	
	XLP00 Front cover with EFM (Electronic Fuse Monitoring)	1SEP101873R0007	0,09
06	XLP00 Front fixing bracket with front frame	1SEP201534R0001	
07	XLP00 Frontframe for 1 XLP00	1SEP407792R0001	0,02
	XLP00 Frontframe for 2 XLP00	1SEP407792R0002	0,03
	XLP00 Frontframe for 3 XLP00	1SEP407792R0003	0,04
08	XLP00 Cable shroud	1SEP407793R0001	0,03
	XLP00 Snap for double DIN rail	1SEP407897R0001	0,24

### Accessories XLP1 - 3-pole

Image n.	Type	Order code	Weight (Kg)
	XLP1 A60/85 Adapter above, 60 mm busbar distance, 5 or 10 mm cable, above	1SEP201451R0001	0,74
	XLP1 A60/85 Adapter below, 60 mm busbar distance, 5 or 10 mm cable, below	1SEP201456R0001	0,74
	XLP1 Front cover with EFM (Electronic Fuse Monitoring)	1SEP101883R0007	0,37
09	XLP1 Frontframe for 1 XLP1	1SEP407815R0001	0,04
10	XLP1 Frontframe for 2 XLP1	1SEP407815R0002	0,06
11	XLP1 Cable shroud	1SEP407793R0002	0,1



06



07



08

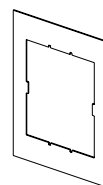

09

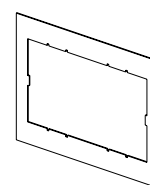

10

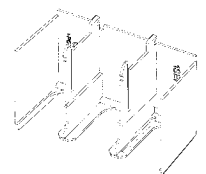

11

—  
**Accessories XLP2/3 - 3-pole**

Image n.	Type	Order code	Weight (Kg)
09	XLP2 Frontframe for 1 XLP2	1SEP407951R0001	0,04
10	XLP2 Frontframe for 2 XLP2	1SEP407951R0002	0,06
	XLP2 Front cover with EFM (Electronic Fuse Monitoring)	1SEP101982R0007	0,25
	XLP3 Frontframe for 1 XLP3	1SEP407955R0001	0,055
	XLP3 Front cover with EFM (Electronic Fuse Monitoring)	1SEP101984R0007	0,35
11	XLP2/3 Cable shroud	1SEP407952R0001	0,18

—  
**Accessories XLP 1-, 2- and 4-pole**

Type	Order code	Weight (Kg)
XLP00-1P Cable Shroud For 1- and 2-Pole and N at the 4-Pole	1SEP618708R0001	0,02
XLP1-1P Cable Shroud For 1- and 2-Pole and N at the 4-Pole	1SEP618709R0001	0,07
XLP2/3-1P Cable Shroud For 1- and 2-Pole and N at the 4-Pole	1SEP618710R0001	0,13
XLP00 1P Front Frame f/1 Device	1SEP407792R0011	0,01
XLP00 1P Front Fr. f/2 1P, f/1 2P Device	1SEP407792R0012	0,02
XLP00 4P Front Frame f/1 Device	1SEP407792R0041	0,02
XLP1 1P Front Frame f/1 Device	1SEP407815R0011	0,03
XLP1 1P Front Fr. f/2 1P, f/1 2P Device	1SEP407815R0012	0,04
XLP1 4P Front Frame f/1 Device	1SEP407815R0041	0,05
XLP1 4P Front Frame f/2 Device	1SEP407815R0042	0,07
XLP2 1P Front Frame f/1 Device	1SEP407951R0011	0,28
XLP2 1P Front Fr. f/2 1P, f/1 2P Device	1SEP407951R0012	0,32
XLP2 4P Front Frame f/1 Device	1SEP407951R0041	0,48
XLP3 1P Front Frame f/1 Device	1SEP407955R0011	0,04
XLP3 2P Front Frame f/1 Device	1SEP407955R0021	0,05
XLP3 4P Front Frame f/1 Device	1SEP407955R0041	0,07

# Ordering information

## Accessories for busbar system

### Accessories for busbar system

Image n.	Description	Order code	Weight 1 piece(Kg)	Quantity (pcs/package)
12	Busbar support 3-pole, for busbar 5-10 x 10-30 mm	GHV 240849R0001	0,17	1/1
13	Universal busbar support for UL 3-pole for busbars 12, 20, 30 x 5, 10 mm	1STQ003872B0000 <sup>1)</sup>		1/10
14	Spacer suitable for 1STQ003872B0000	1STQ003873B0000 <sup>1)</sup>		1/10
15	End cover 3-pole for busbar support 1STQ003872B0000	1STQ003874B0000 <sup>1)</sup>		1/10
16	Cable connection supply module, for busbar 5-10 x 10-30 mm or cable 35 - 120 mm <sup>2</sup>	GHV 240849R0034	0,62	1/1

1) For more information refer to the catalog System pro E Power, Chapter 5, code 1STC803005D0203



12



13



14



15



16

—  
**Busbar <sup>1)</sup>**  
**Tinned flat busbars**

Description	Current carrying capacities at busbar temperature		International standard		Order code	Quantity (pcs/package)
	65°C	85°C	IEC	UL		
Busbar 20x5 length 2,4m, tinned	320A	400A	■	■	1STQ004344B0000	1/1
Busbar 30x5 length 2,4m, tinned	450A	550A	■	■	1STQ004345B0000	1/1
Busbar 20x10 length 2,4m, tinned	520A	630A	■	■	1STQ004346B0000	1/1
Busbar 30x10 length 2,4m, tinned	630A	800A	■	■	1STQ004347B0000	1/1

—  
**Busbar covers <sup>1)</sup>**  
**In plastic for busbars protection, length 1m**

Description	International standard		Order code	Quantity (pcs/package)
	IEC	UL		
Busbar protection cover for 12/30x5 flat bars, 1m	■	■	1STQ003885B0000	1/10
Busbar protection cover for 12/30x10 flat bars, 1m	■	■	1STQ003886B0000	1/10

1) For more information refer to the catalog System pro E Power, Chapter 5, code 1STC803005D0203



—  
 Busbar



—  
 Busbar covers

# Ordering information

## Accessories for XLPD0

### Accessories for XLPD0

Image n.	Description	Order code	Weight 1 piece(Kg)	Quantity (pcs/package)
17	9 mm side module for XLPD0-FS-E18-3P	1SEP622389R0001	0,1	1/5
18	D02 reducer for D01 fuses 2-16A	2CDE000011R1901 <sup>1)</sup>	0,001	1/20
19	Spring clip for use of D01 fuses in D02 screw caps	GMN 977 130 P0004 <sup>1)</sup>	0,001	1/50

1) For more information refer to the catalog Solutions for electrical installation in buildings, Chapter 5, code 2CHC000001C0202

### D0 fuse links to DIN VDE 0636-3, IEC/EN 60269-3 <sup>1)</sup>

Rated current [A]	Colour code	Power loss (W)	Type	Order code	Weight 1 piece (Kg)	Quantity (pcs/package)
<b>Suitable for D01/E14</b>						
2	pink	1,5	D01 x 2 gG	GNM 977 120 P0011	0,006	10
4	brown	1,5	D01 x 4 gG	GNM 977 120 P0012	0,006	10
6	green	1,5	D01 x 6 gG	GNM 977 120 P0013	0,006	10
10	red	1,8	D01 x 10 gG	GNM 977 120 P0014	0,006	10
16	grey	2,1	D01 x 16 gG	GNM 977 120 P0015	0,006	10
<b>Suitable for D02/E18</b>						
20	blue	2.3	D02 x 20 gG	GNM 977 120 P0017	0,011	10
25	yellow	2.6	D02 x 25 gG	GNM 977 120 P0018	0,012	10
35	black	2.9	D02 x 35 gG	GNM 977 120 P0019	0,013	10
50	white	3.5	D02 x 50 gG	GNM 977 120 P0020	0,014	10
63	copper	4.2	D02 x 63 gG	GNM 977 120 P0021	0,015	10

1) For more information refer to the catalog Solutions for electrical installation in buildings, Chapter 5, code 2CHC000001C0202



17



18



19



Fuse links



—  
D0 fuse links to DIN VDE 0636-3, IEC/EN 60269-3 <sup>1)</sup>

Rated current [A]	Colour code	Power loss (W)	Type	Order code	Weight 1 piece (Kg)	Quantity (pcs/package)
<b>D0 screw caps acc. to DIN VDE 0636-3, IEC/EN 60269-3, 400 V AC</b>						
<b>Plastic version, RAL 7037</b>						
16	for D01	-	D01 DIN 49 525 K	GMN 977 130 P0011	0,015	20
63	for D02	-	D02 DIN 49 525 K	GMN 977 130 P0012	0,015	20
<b>D0 connector sleeves to DIN VDE 0636-3, IEC/EN 60269-3</b>						
<b>Suitable for D01/E14</b>						
2	pink	-	D01 x 2	GMN 977 125 P0001	0,001	50
4	brown	-	D01 x 4	GMN 977 125 P0002	0,001	50
6	green	-	D01 x 6	GMN 977 125 P0003	0,001	50

1) For more information refer to the catalog Solutions for electrical installation in buildings, Chapter 5, code 2CHC000001C0202

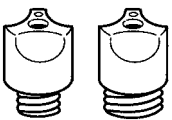

—  
D0 screw caps



—  
Connector sleeves

# Technical Data

## XLP 1-pole

		XLP00			XLP1			XLP2			XLP3		
For NH fuse links acc. to IEC60269-2-1		NH000/NH00			NH1			NH2			NH3		
Rated operational voltage U <sub>e</sub> AC	(V)	-	500	690	-	500	690	-	500	690	-	500	690
Rated operational voltage U <sub>e</sub> DC	(V)	220	-	-	220	-	-	220	-	-	220	-	-
Rated operational current I <sub>e</sub>	(A)	160	160	125	250	250	200	400	400	315	630	630	500
Thermal current with fuse-link I <sub>th</sub>	(A)	160	160	160	250	250	250	400	400	-	630	630	-
Utilization category		DC22B	AC22B	AC21B	DC22B	AC22B	AC21B	DC22B	AC22B	AC21B	DC22B	AC22B	AC21B
Rated insulation voltage U <sub>i</sub>	(V)	1000			1000			1000			1000		
Rated impulse withstand voltage U <sub>imp</sub>	(kV)	8			8			8			8		
Rated conditional short circuit current	(kArms)	50			50			50			50		
Rated frequency	(Hz)	50 - 60			50 - 60			50 - 60			50 - 60		
Power loss (I <sub>th</sub> ) without fuselink, per phase	(W)	3,5			7,5			13			24		
Electrical durability		200			200			200			200		
Mechanical durability		1400			1400			800			800		
Degree of protection from the front according to IEC60529	Open	IP20			IP20			IP20			IP20		
	Closed	IP30			IP30			IP30			IP30		

## XLP 2-pole

		XLP00			XLP1			XLP2			XLP3		
For NH fuse links acc. to IEC60269-2-1		NH000/NH00			NH1			NH2			NH3		
Rated operational voltage U <sub>e</sub> AC	(V)	-	500	690	-	500	690	-	500	690	-	500	690
Rated operational voltage U <sub>e</sub> DC	(V)	220	-	-	440	-	-	440	-	-	440	-	-
Rated operational current I <sub>e</sub>	(A)	160	160	125	250	250	200	400	400	315	630	630	500
Thermal current with fuse-link I <sub>th</sub>	(A)	160	160	160	250	250	250	400	400	-	630	630	-
Utilization category		DC22B	AC22B	AC21B	DC22B	AC22B	AC21B	DC22B	AC22B	AC21B	DC22B	AC22B	AC21B
Rated insulation voltage U <sub>i</sub>	(V)	1000			1000			1000			1000		
Rated impulse withstand voltage U <sub>imp</sub>	(kV)	8			8			8			8		
Rated conditional short circuit current	(kArms)	50			50			50			50		
Rated frequency	(Hz)	50 - 60			50 - 60			50 - 60			50 - 60		
Power loss (I <sub>th</sub> ) without fuselink, per phase	(W)	3,5			7,5			13			24		
Electrical durability		200			200			200			200		
Mechanical durability		1400			1400			800			800		
Degree of protection from the front according to IEC60529	Open	IP20			IP20			IP20			IP20		
	Closed	IP30			IP30			IP30			IP30		

—  
**XLP 3-pole**

		XLP000			XLP00			XLP1			XLP2		XLP3	
For NH fuse links acc. to IEC60269-2-1		NH000/NH00C max width = 21 mm			NH000/NH00			NH1			NH2		NH3	
Rated operational voltage $U_e$ AC	(V)	400	500	690	400	500	690	500	800	690	500	690	500	690
Rated operational current $I_e$ AC	(A)	80	100	50	125	160	125	250	160	200	400	315	630	500
Thermal current with fuse link $I_{th}$	(A)	100			160			250			400		630	
Utilization category		AC23B	AC22B	AC21B	AC23B	AC22B	AC21B	AC22B	AC22B	AC21B	AC22B	AC21B	AC22B	AC21B
Rated insulation voltage $U_i$	(V)	690			1000			1000			1000		1000	
Rated impulse withstand voltage $U_{imp}$	(kV)	6			8			8			8		8	
Rated conditional short circuit current	(kArms)	50			50			50			50		50	
Rated frequency	(Hz)	50 - 60			50 - 60			50 - 60			50 - 60		50 - 60	
Power loss at $I_{th}$ without fuse link/per phase	(W)	1,4W			3,5W			7,5W			13W		24W	
Max allowed poweloss in the Fuse per phase	(W)	7,5W			12W			23W			30W		48W	
Electrical durability		300			200			200			200		200	
Mechanical durability		1700			1400			1400			800		800	
Degree of protection from the front acc. to IEC60529	Open	IP20			IP20 <sup>1)</sup>			IP20 <sup>1)</sup>			IP20 <sup>1)</sup>		IP20 <sup>1)</sup>	
	Closed	IP30			IP30 <sup>1)</sup>			IP30 <sup>1)</sup>			IP30 <sup>1)</sup>		IP30 <sup>1)</sup>	

—  
**XLP 4-pole**

		XLP00		XLP1		XLP2		XLP3	
For NH fuse links acc. to IEC60269-2-1		NH000/NH00		NH1		NH2		NH3	
Rated operational voltage $U_e$ AC	(V)	500		500		500		500	
Rated operational current $I_e$	(A)	160		250		400		630	
Thermal current with fuse-link $I_{th}$	(A)	160		250		400		630	
Utilization category		AC22B		AC22B		AC22B		AC22B	
Rated insulation voltage $U_i$	(V)	1000		1000		1000		1000	
Rated impulse withstand voltage $U_{imp}$	(kV)	8		8		8		8	
Rated conditional short circuit current	(kArms)	50		50		50		50	
Rated frequency	(Hz)	50 - 60		50 - 60		50 - 60		50 - 60	
Power loss ( $I_{th}$ ) without fuselink, per phase	(W)	3,5		7,5		13		24	
Electrical durability		200		200		200		200	
Mechanical durability		1400		1400		800		800	
Degree of protection from the front according to IEC60529	Open	IP20		IP20		IP20		IP20	
	Closed	IP30		IP30		IP30		IP30	

# Technical Data

## XLPD0 3-pole

Fuse links Fuse size	XLPD0-FS-E18-3P D01 <sup>1)</sup> , D02	XLPD0-FB-E18/27-3P D02	XLPD0-FB-E18/36-3P D02	XLPD0-FB-E27/42-3P DII	XLPD0-FB-E33/57-3P DIII	XLPD0-FS-1038-3P <sup>2)</sup> NFC 10x38	
Rated operational voltage U <sub>e</sub> AC (V)	400	400	400	500	500	500	690
Rated operational voltage U <sub>e</sub> DC (V)		250	250	500	500		
Rated operational current I <sub>e</sub>	63	63	63	25	63		32
Utilization category	AC-22B						AC-21B
Rated insulation voltage U <sub>i</sub> (V)	500						800
Rated impulse withstand voltage U <sub>imp</sub> (kV)	6	6	6	6	6		6
Rated conditional short circuit current (kArms)	50	50 (AC) / 8 (DC)	50 (AC) / 8 (DC)	50 (AC) / 8 (DC)	50 (AC) / 8 (DC)		100
Rated frequency (Hz)	50	50	50	50	50		50
Power loss (I <sub>th</sub> ) without fuselink (W)	7	5,9	5,9	1,2	10		1
Max allowed poweloss in the Fuse per phase (W)	5,5	5,5	5,5	4	7		3

1) Together with D02 reducer part 2CDE000011R190 also suitable for fuse links D01

2) UL -ratings Operational current 30A and operational voltage 600 V (AC/DC) at 50kA



# Dimensional drawings

## XLP000

### XLP000

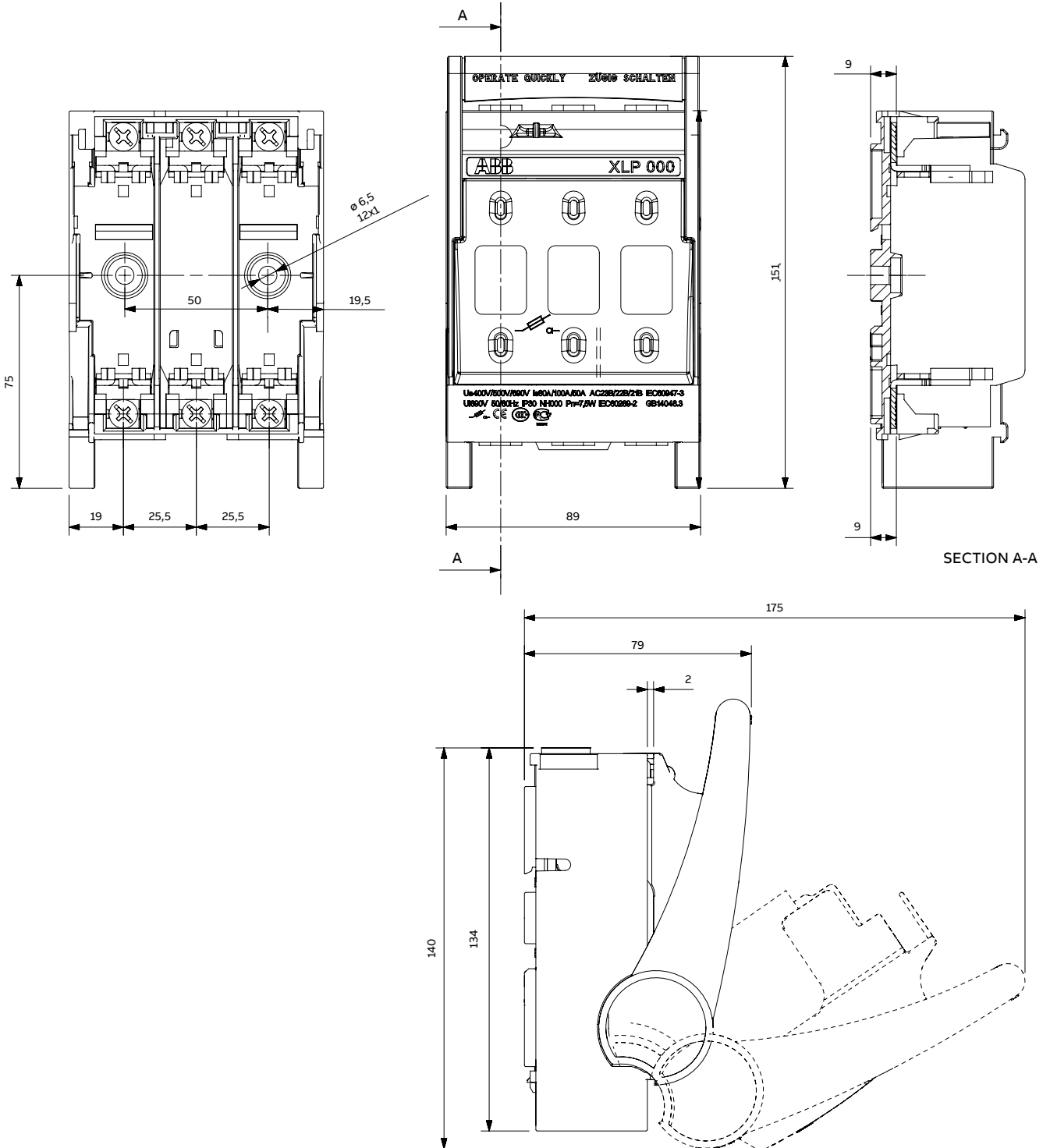

# Dimensional drawings

## XLP00 and XLP1

### XLP00

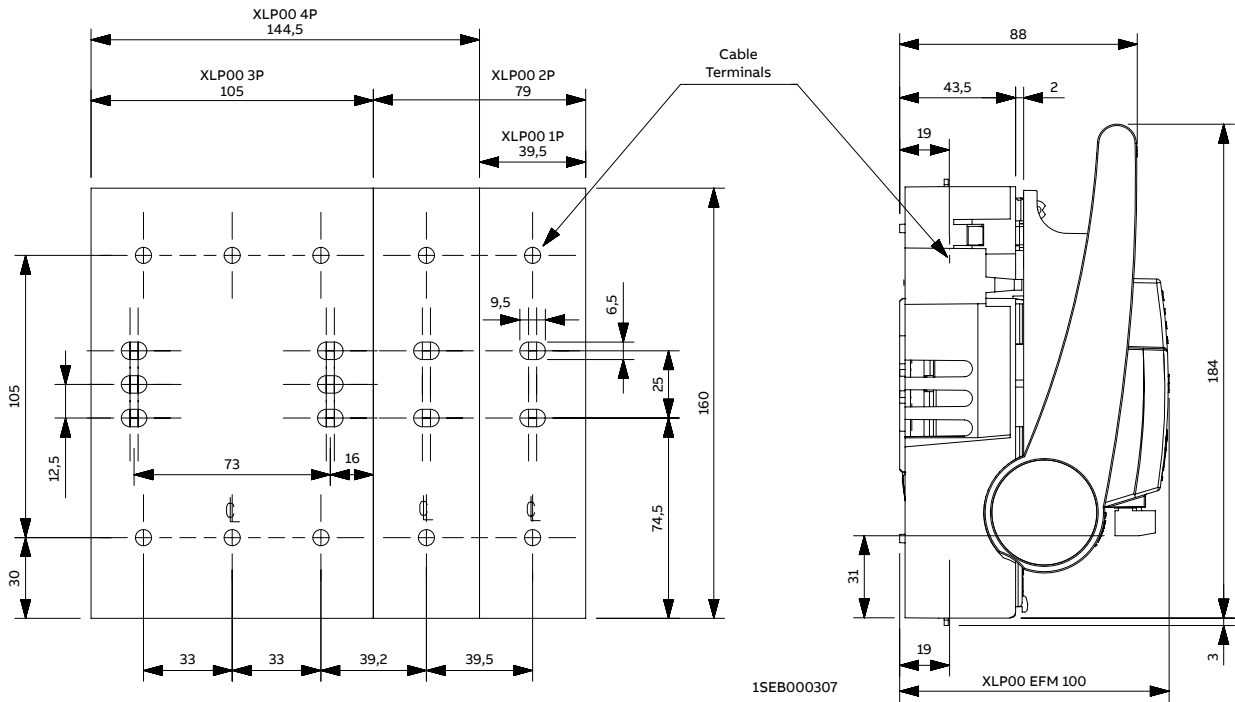

### XLP1

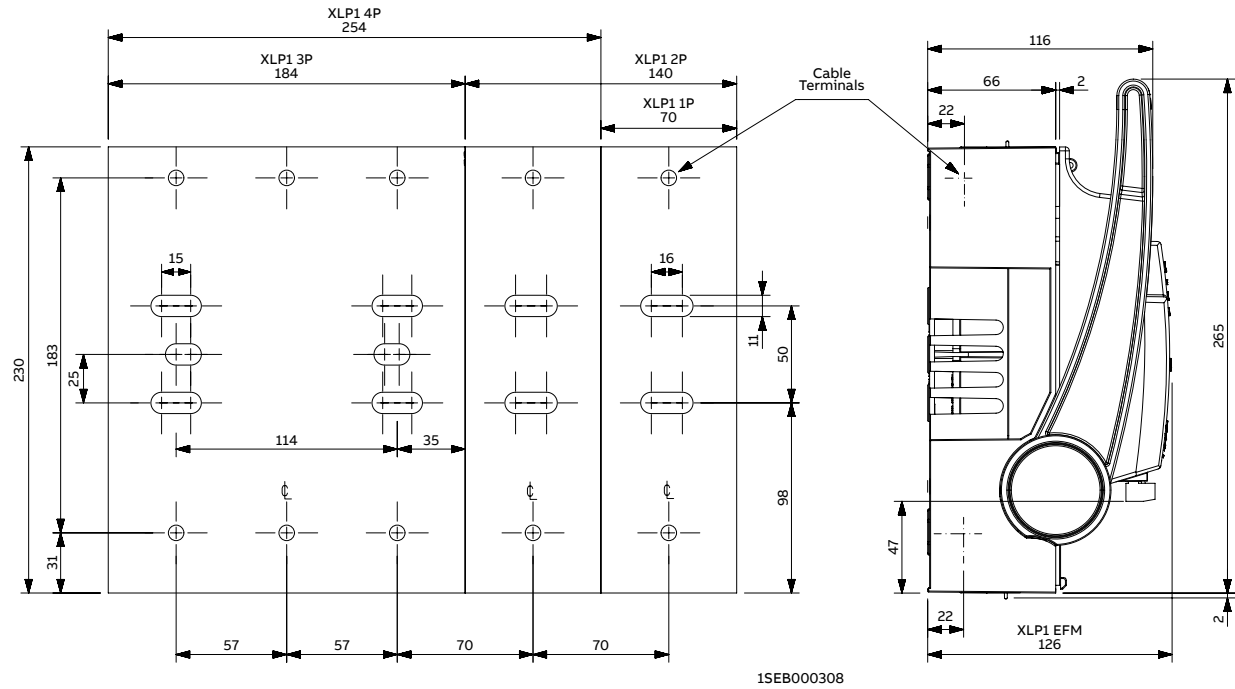

# Dimensional drawings

## XLP2 and XLP3

### XLP2

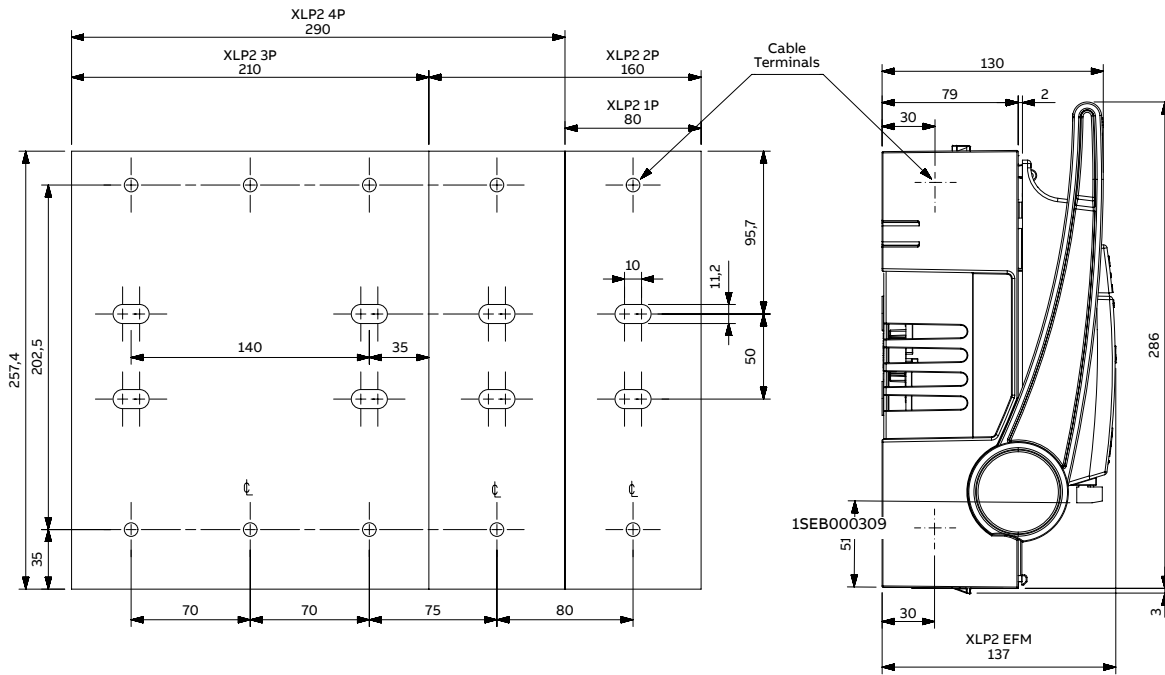

### XLP3

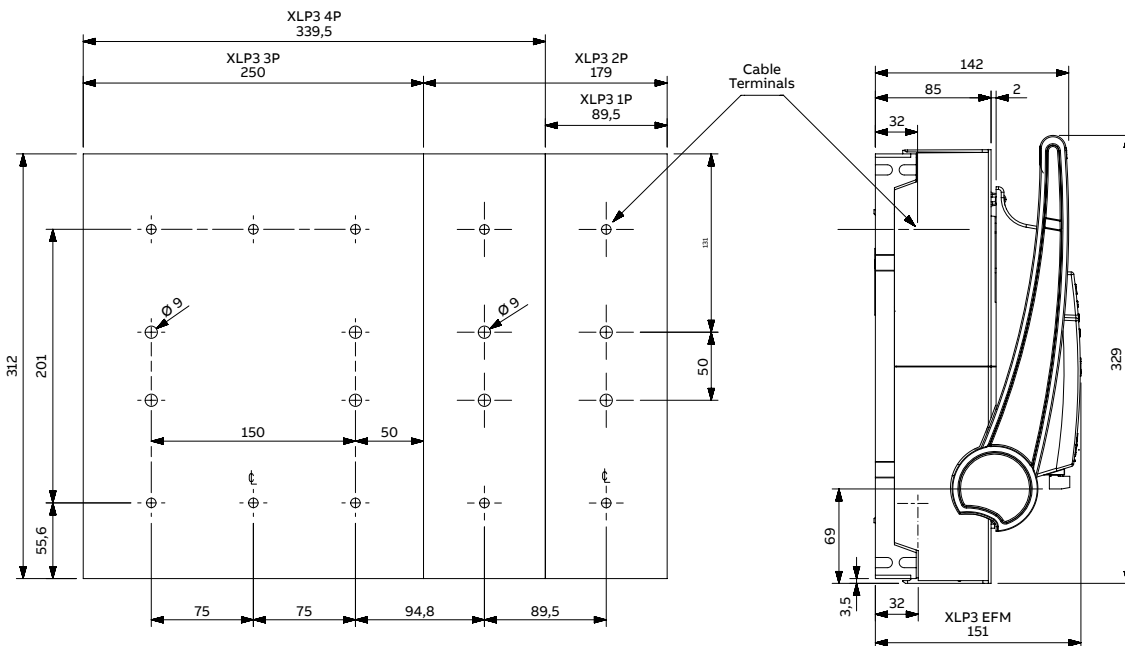



# Dimensional drawings

## Busbar Adapters XLP00

### XLP00 – A40/75

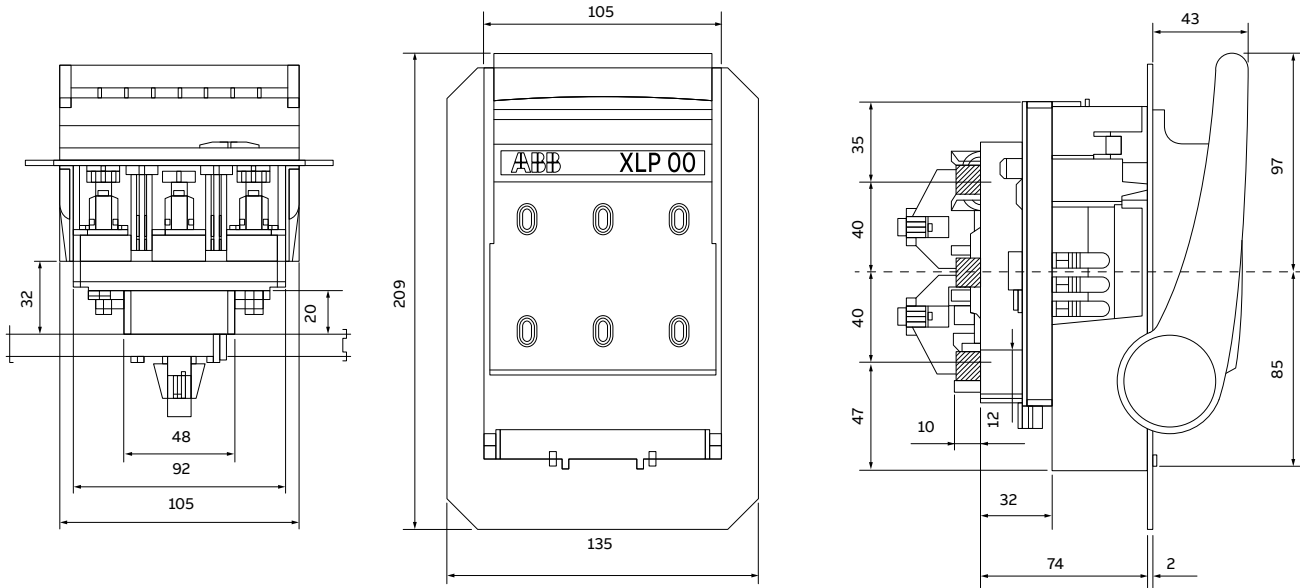

### XLP00 – A40/95

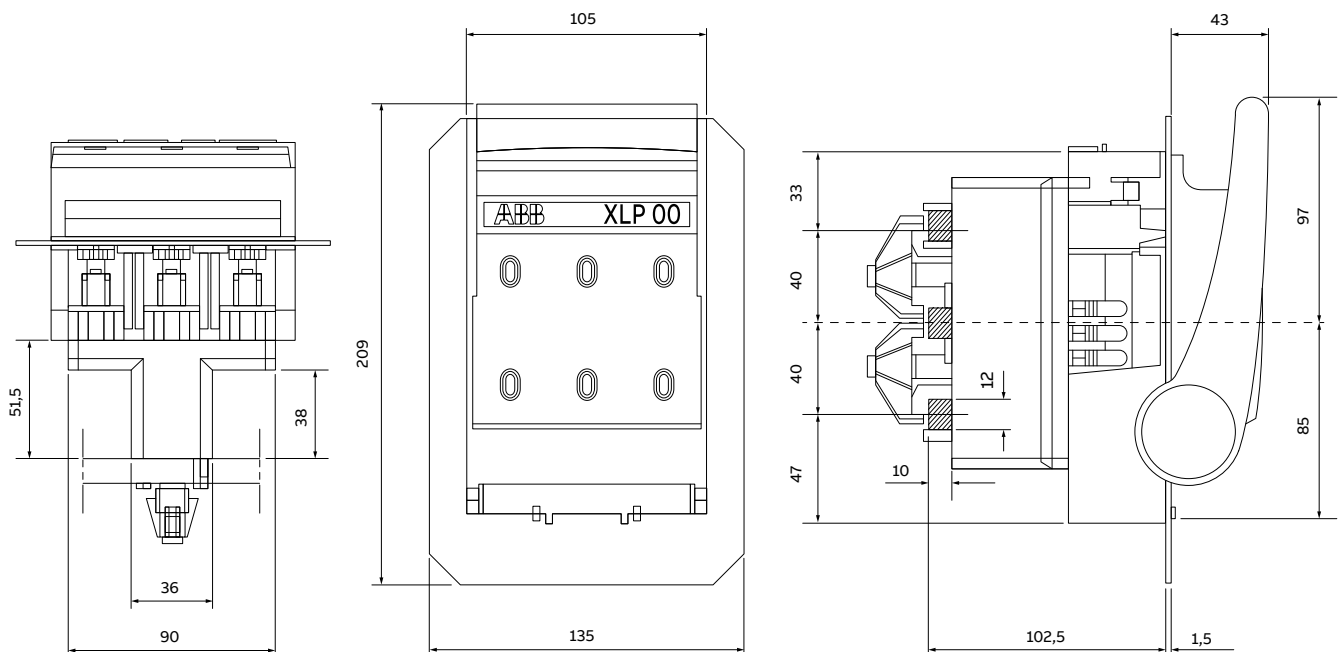

# Dimensional drawings

## Busbar Adapters XLP00

**XLP00 – A40/120**

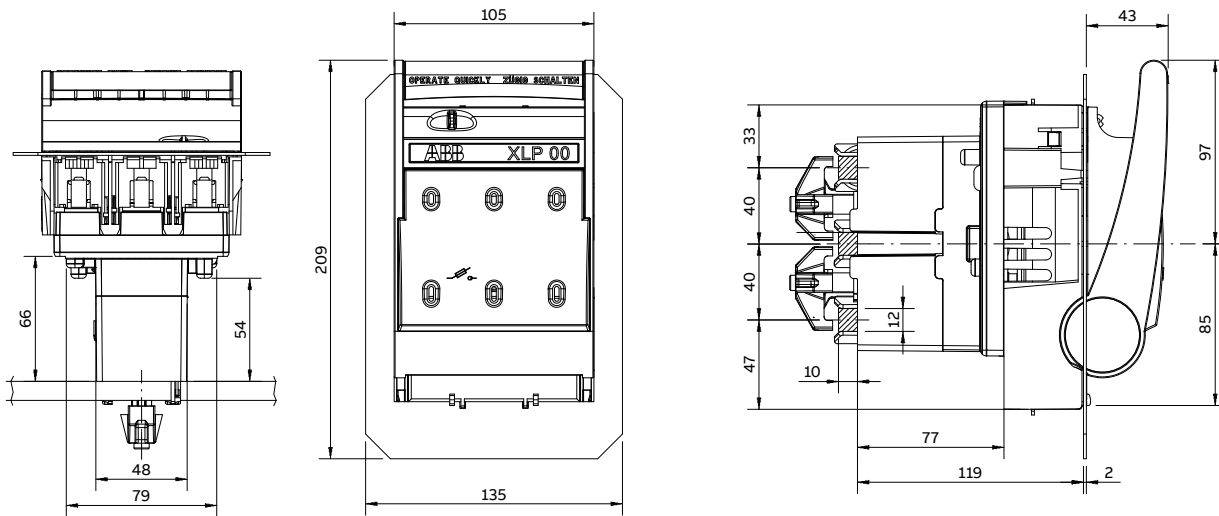

1SEB000005

**XLP00 – A60/60**

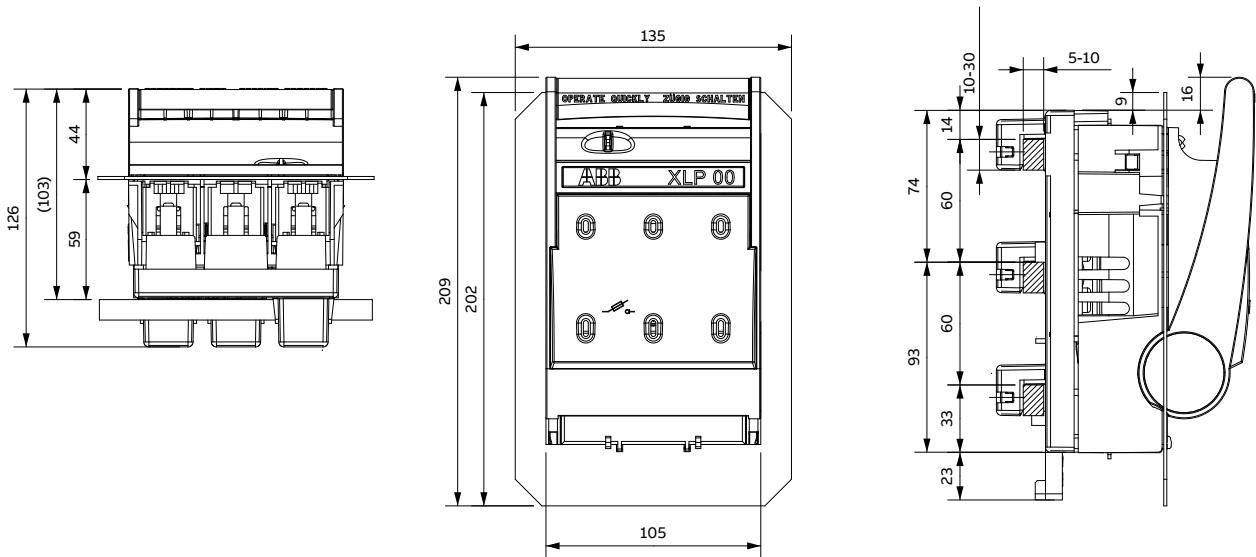

1SEB000007

# Dimensional drawings

## Busbar Adapters XLP1

### XLP1-A60/85

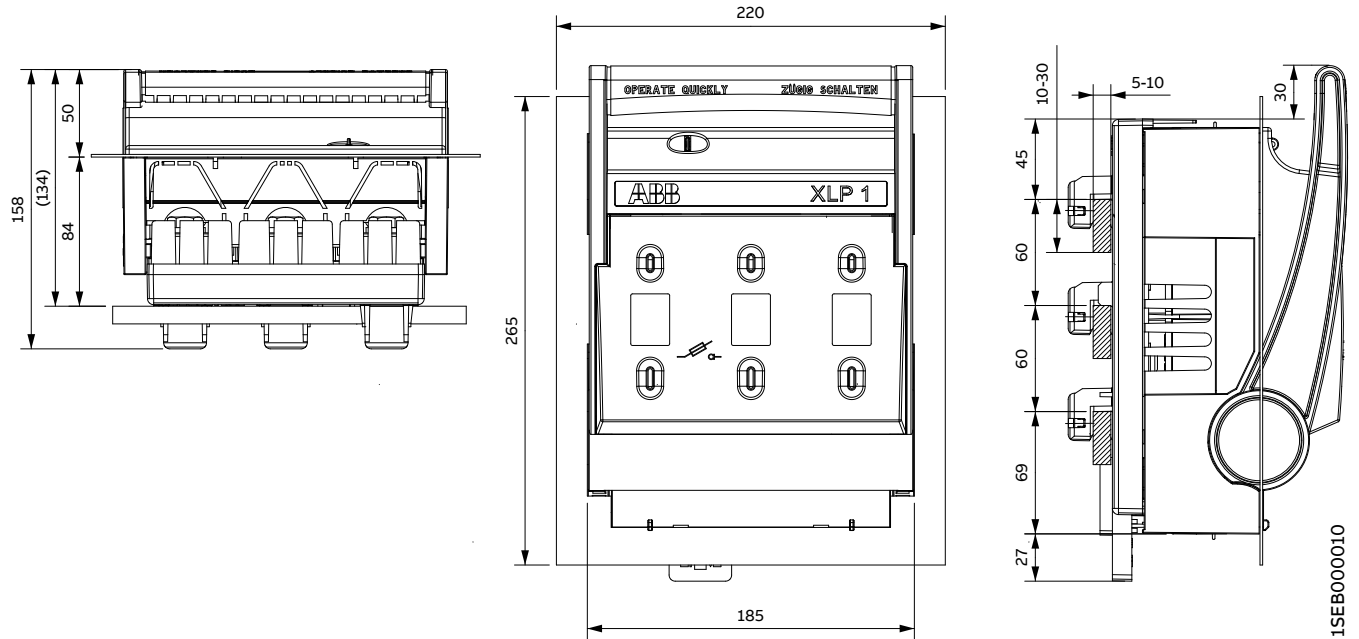

### XLP1-A40/120

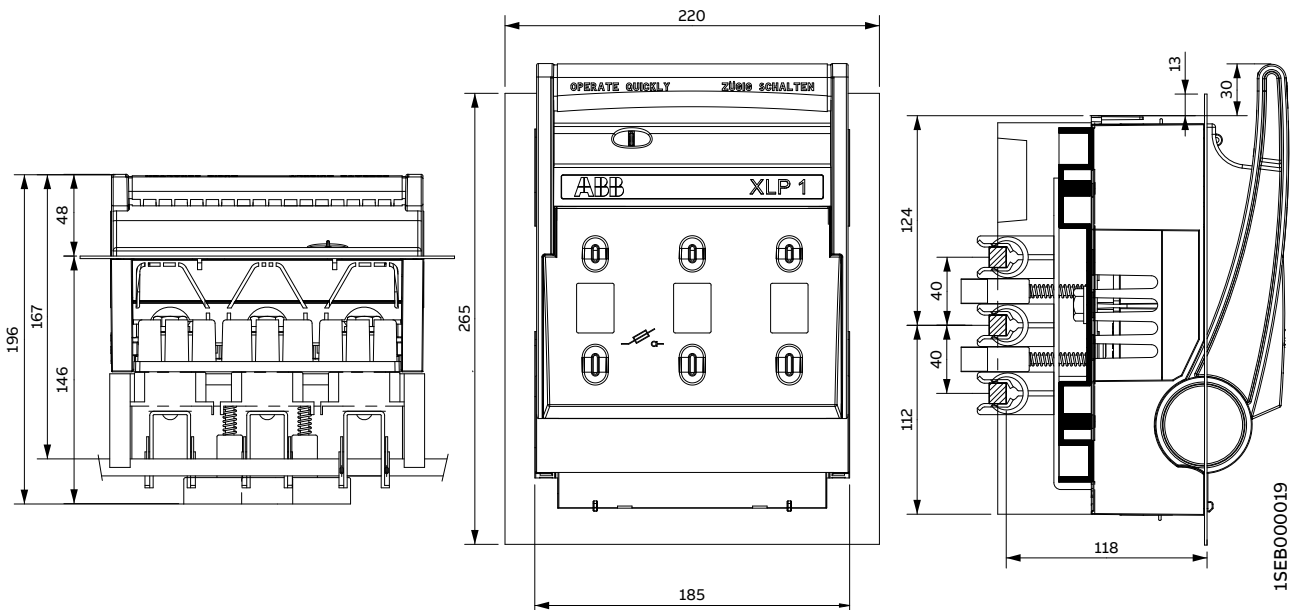

# Dimensional drawings

## Busbar Adapters XLP2 and XLP3

**XLP2 – A60/120**

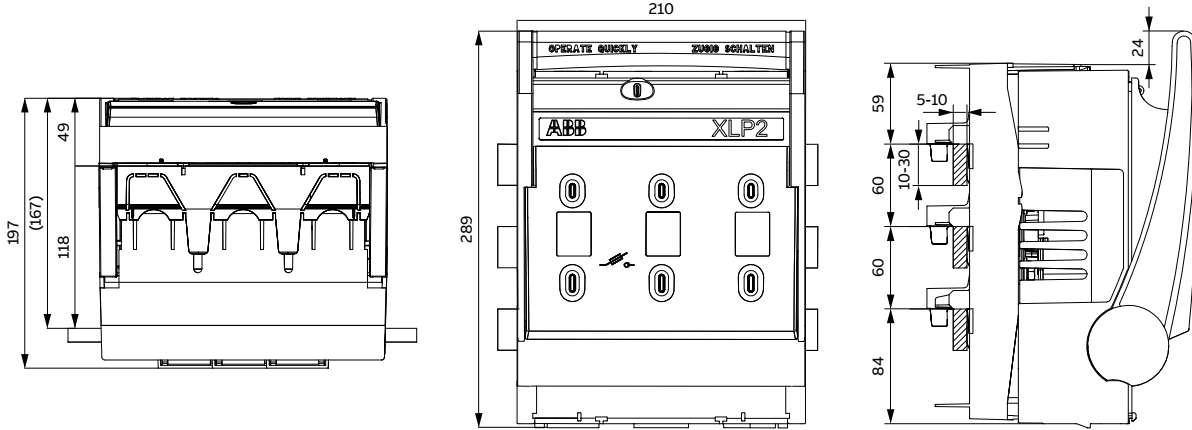

**XLP3 – A60/120**

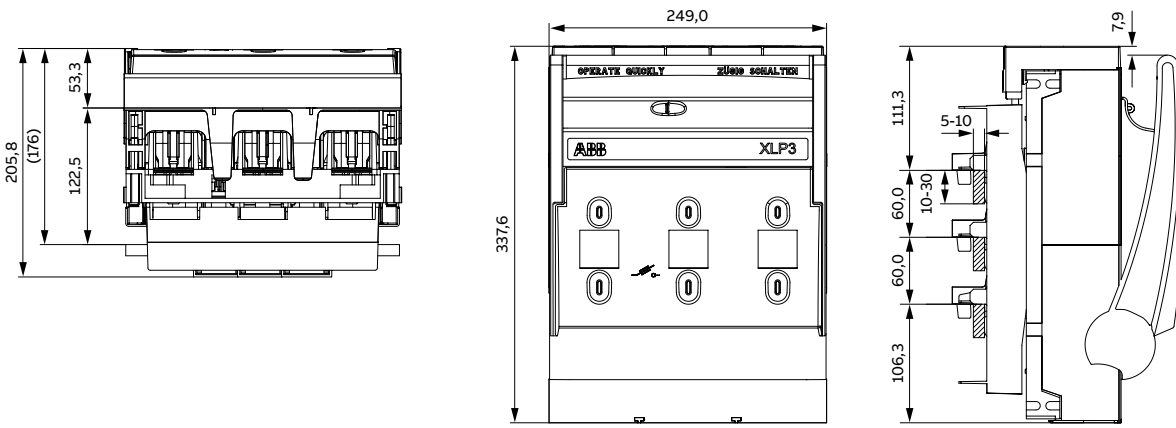

XLP3 A60/120 Below

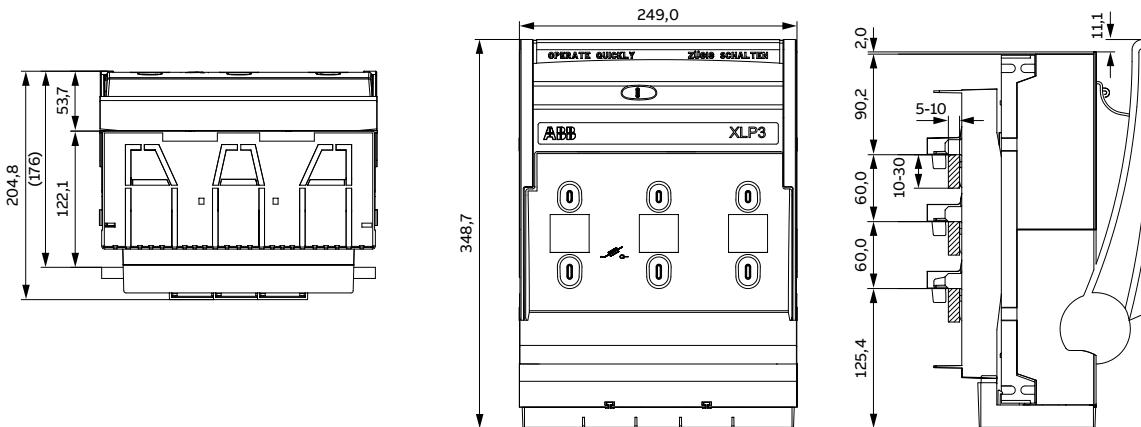

XLP3 A60/120 Above

# Dimensional drawings

## XLPD0

XLPD0-FB-E18/27-3P

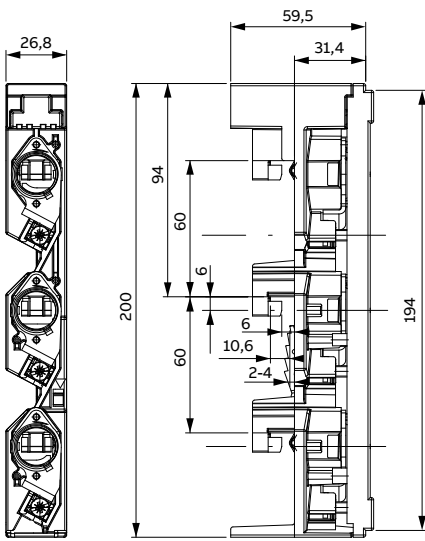

XLPD0-FB-E18/36-3P

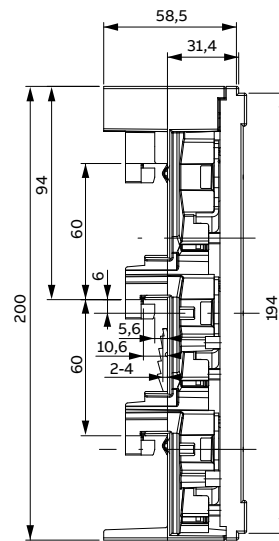

XLPD0-FB-E27/42-3P

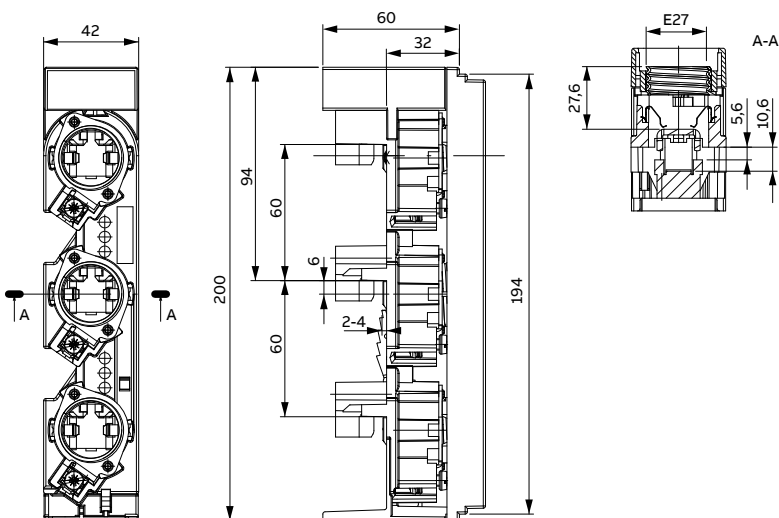

# Dimensional drawings

## XLPD0

**XLPD0-FB-E33/57-3P**

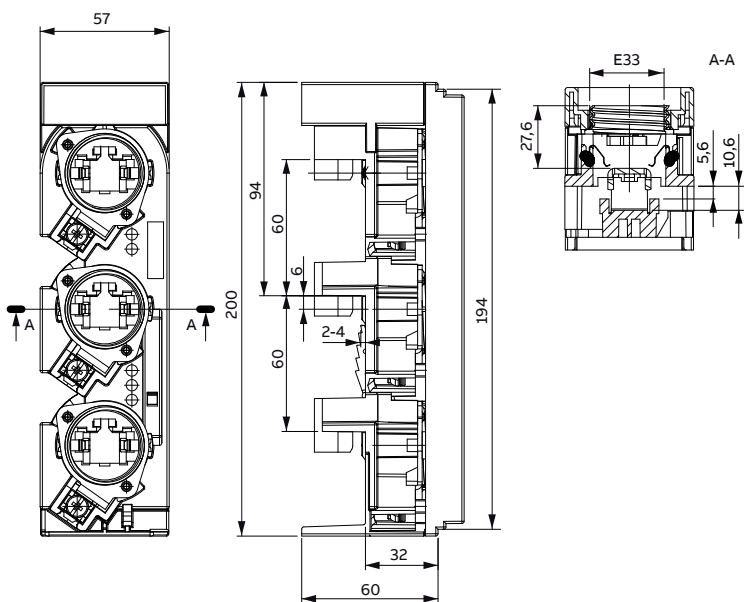

**XLPD0-FS-1038-3P**

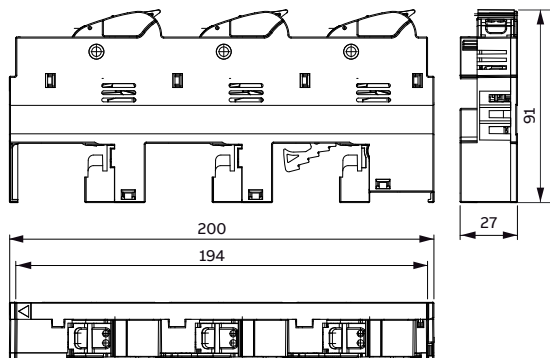

**XLPD0-FS-E18-3P**

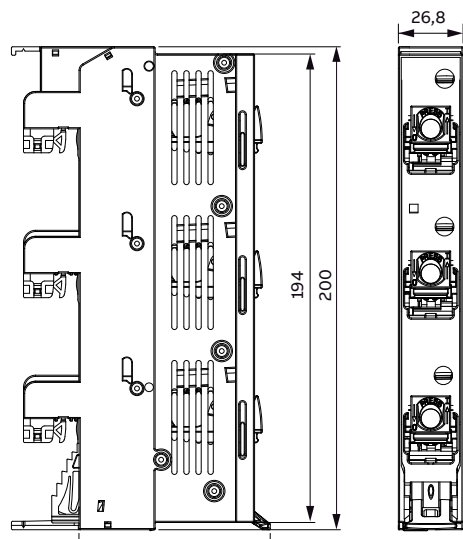



—  
**ABB Oy**  
**Protection and Connection**

P.O. Box 622  
FI-65101 Vaasa  
Finland

**[www.abb.com](http://www.abb.com)**

Find the address of your local sales organization on the ABB homepage:

**[www.abb.com/contacts](http://www.abb.com/contacts)**  
**> Low Voltage Products and Systems**

**Additional information**

We reserve the right to make technical changes or modify the contents of this document without prior notice. With regard to purchase orders, the agreed particulars shall prevail. ABB does not accept any responsibility whatsoever for potential errors or possible lack of information in this document.

We reserve all rights in this document and in the subject matter and illustrations contained therein. Any reproduction, disclosure to third parties or utilization of its contents – in whole or in parts – is forbidden without prior written consent of ABB.

© Copyright 2021 ABB. All rights reserved.

