

AWK-3131A-RTG Series

Rail onboard indoor single radio, 802.11n AP/client, IP30



Features and Benefits

- IEEE 802.11a/b/g/n compliant
- M12 anti-vibration connectors
- SC optical fiber connection
- QoS (WMM) and VLAN for efficient network traffic
- Controller-based Turbo Roaming (less than 50 ms)¹
- Complies with all EN 50155 mandatory test items²
- Wide-temperature models available for -40 to 75°C environments

Certifications



Introduction

The AWK-3131A-RTG 2-in-1 industrial AP/client devices are designed specifically for train-to-ground communication and can perform reliably even when the trains reach a speed of 120 km/h. The AWK-3131A-RTG complies with a portion of EN 50155 specifications, covering operating temperature, power input voltage, surge, ESD, and vibration, making the AWK-3131A-RTG suitable for a variety of industrial applications. Installation is easy, with either DIN-rail mounting or distribution boxes, and the DIN-rail mounting capability, wide operating temperature range, and IP30 housing with LED indicators make the AWK-3131A-RTG a convenient yet reliable solution for any rolling stock application.

Advanced Security

- 64-bit and 128-bit WEP (Wired Equivalent Privacy)
- Enable/disable SSID broadcasts
- WPA/WPA2 (Wi-Fi Protected Access) and 802.11i support
- IEEE802.1X/RADIUS support
- Powerful filters for access control

Designed for Train-to-Ground Applications

- Client-based Turbo Roaming handover time < 150 ms @ 3 channel with WPA2
- Controller-based Turbo Roaming handover time (available only when used with the WAC-1001 or WAC-2004) < 50 ms @ 3 channels with WPA2
- Multiple roaming parameters for different installation structures and antenna types

Specifications

WLAN Interface

WLAN Standards	802.11a/b/g/n 802.11i Wireless Security
Modulation Type	DSSS OFDM 802.11b: CCK @ 11/5.5 Mbps 802.11b: DQPSK @ 2 Mbps 802.11b: DBPSK @ 1 Mbps 802.11a/g: 64QAM @ 54/48 Mbps 802.11a/g: 16QAM @ 36/24 Mbps 802.11a/g: QPSK @ 18/12 Mbps 802.11a/g: BPSK @ 9/6 Mbps 802.11n: 64QAM @ 300 Mbps to BPSK @ 6.5 Mbps

1. The Turbo Roaming recovery time indicated herein is an average of test results documented, in optimized conditions, across APs configured with interference-free 20-MHz RF channels, WPA2-PSK security, and default Turbo Roaming parameters. The clients are configured with 3-channel roaming at 100 Kbps traffic load. Other conditions may also impact roaming performance. For more information about Turbo Roaming parameter settings, refer to the product manual.
2. This product is suitable for rolling stock railway applications, as defined by the EN 50155 standard. For a more detailed statement, click here: www.moxa.com/doc/specs/EN_50155_Compliance.pdf

Frequency Band for US (20 MHz operating channels)	2.412 to 2.462 GHz (11 channels) 5.180 to 5.240 GHz (4 channels) 5.260 to 5.320 GHz (4 channels) ³ 5.500 to 5.700 GHz (8 channels) excluding 5.600 to 5.640 GHz ⁴ 5.745 to 5.825 GHz (5 channels)
Frequency Band for EU (20 MHz operating channels)	2.412 to 2.472 GHz (13 channels) 5.180 to 5.240 GHz (4 channels) 5.260 to 5.320 GHz (4 channels) ³ 5.500 to 5.700 GHz (11 channels) ⁴
Frequency Band for JP (20 MHz operating channels)	2.412 to 2.484 GHz (14 channels) 5.180 to 5.240 GHz (4 channels) 5.260 to 5.320 GHz (4 channels) ³ 5.500 to 5.700 GHz (11 channels) ³
Wireless Security	SSID broadcast enable/disable WEP encryption (64-bit and 128-bit) WPA/WPA2-Personal WPA/WPA2-Enterprise (IEEE 802.1X/RADIUS, TKIP, AES)
Transmission Rate	802.11b: 1 to 11 Mbps 802.11a/g: 6 to 54 Mbps 802.11n: 6.5 to 300 Mbps
Transmitter Power for 802.11a	23±1.5 dBm @ 6 to 24 Mbps 21±1.5 dBm @ 36 Mbps 20±1.5 dBm @ 48 Mbps 18±1.5 dBm @ 54 Mbps
Transmitter Power for 802.11n (5 GHz)	23±1.5 dBm @ MCS0 20 MHz 20±1.5 dBm @ MCS1 20 MHz 20±1.5 dBm @ MCS2 20 MHz 20±1.5 dBm @ MCS3 20 MHz 19±1.5 dBm @ MCS4 20 MHz 18±1.5 dBm @ MCS5 20 MHz 18±1.5 dBm @ MCS6 20 MHz 18±1.5 dBm @ MCS7 20 MHz 23±1.5 dBm @ MCS8 20 MHz 20±1.5 dBm @ MCS9 20 MHz 20±1.5 dBm @ MCS10 20 MHz 20±1.5 dBm @ MCS11 20 MHz 19±1.5 dBm @ MCS12 20 MHz 19±1.5 dBm @ MCS13 20 MHz 18±1.5 dBm @ MCS14 20 MHz 18±1.5 dBm @ MCS15 20 MHz 23±1.5 dBm @ MCS0 40 MHz 20±1.5 dBm @ MCS1 40 MHz 20±1.5 dBm @ MCS2 40 MHz 20±1.5 dBm @ MCS3 40 MHz 19±1.5 dBm @ MCS4 40 MHz 18±1.5 dBm @ MCS5 40 MHz 18±1.5 dBm @ MCS6 40 MHz 18±1.5 dBm @ MCS7 40 MHz 23±1.5 dBm @ MCS8 40 MHz 20±1.5 dBm @ MCS9 40 MHz 20±1.5 dBm @ MCS10 40 MHz 20±1.5 dBm @ MCS11 40 MHz 19±1.5 dBm @ MCS12 40 MHz 19±1.5 dBm @ MCS13 40 MHz 18±1.5 dBm @ MCS14 40 MHz 18±1.5 dBm @ MCS15 40 MHz
Transmitter Power for 802.11b	26±1.5 dBm @ 1 Mbps 26±1.5 dBm @ 2 Mbps 26±1.5 dBm @ 5.5 Mbps 25±1.5 dBm @ 11 Mbps

3. DFS (Dynamic Frequency Selection) channel support: In AP mode, when a radar signal is detected, the device will automatically switch to another channel. However, according to regulations, after switching channels, a 60-second availability check period is required before starting the service.
4. DFS (Dynamic Frequency Selection) channel support: In AP mode, when a radar signal is detected, the device will automatically switch to another channel. However according to regulations, after switching channels, a 60-second availability check period is required before starting the service.

Transmitter Power for 802.11g	<p>23±1.5 dBm @ 6 to 24 Mbps 21±1.5 dBm @ 36 Mbps 19±1.5 dBm @ 48 Mbps 18±1.5 dBm @ 54 Mbps</p>
Transmitter Power for 802.11n (2.4 GHz)	<p>23±1.5 dBm @ MCS0 20 MHz 21±1.5 dBm @ MCS1 20 MHz 21±1.5 dBm @ MCS2 20 MHz 21±1.5 dBm @ MCS3 20 MHz 20±1.5 dBm @ MCS4 20 MHz 19±1.5 dBm @ MCS5 20 MHz 18±1.5 dBm @ MCS6 20 MHz 18±1.5 dBm @ MCS7 20 MHz 23±1.5 dBm @ MCS8 20 MHz 21±1.5 dBm @ MCS9 20 MHz 21±1.5 dBm @ MCS10 20 MHz 21±1.5 dBm @ MCS11 20 MHz 20±1.5 dBm @ MCS12 20 MHz 19±1.5 dBm @ MCS13 20 MHz 18±1.5 dBm @ MCS14 20 MHz 18±1.5 dBm @ MCS15 20 MHz 23±1.5 dBm @ MCS0 40 MHz 20±1.5 dBm @ MCS1 40 MHz 20±1.5 dBm @ MCS2 40 MHz 20±1.5 dBm @ MCS3 40 MHz 19±1.5 dBm @ MCS4 40 MHz 19±1.5 dBm @ MCS5 40 MHz 18±1.5 dBm @ MCS6 40 MHz 17±1.5 dBm @ MCS7 40 MHz 23±1.5 dBm @ MCS8 40 MHz 20±1.5 dBm @ MCS9 40 MHz 20±1.5 dBm @ MCS10 40 MHz 20±1.5 dBm @ MCS11 40 MHz 20±1.5 dBm @ MCS12 40 MHz 19±1.5 dBm @ MCS13 40 MHz 18±1.5 dBm @ MCS14 40 MHz 17±1.5 dBm @ MCS15 40 MHz</p>
Receiver Sensitivity for 802.11a (measured at 5.680 GHz)	<p>Typ. -90 @ 6 Mbps Typ. -88 @ 9 Mbps Typ. -88 @ 12 Mbps Typ. -85 @ 18 Mbps Typ. -81 @ 24 Mbps Typ. -78 @ 36 Mbps Typ. -74 @ 48 Mbps Typ. -74 @ 54 Mbps Note⁵</p>
Receiver Sensitivity for 802.11n (5 GHz; measured at 5.680 GHz)	<p>Typ. -88 dBm @ MCS0 20 MHz Typ. -85 dBm @ MCS1 20 MHz Typ. -82 dBm @ MCS2 20 MHz Typ. -79 dBm @ MCS3 20 MHz Typ. -76 dBm @ MCS4 20 MHz Typ. -71 dBm @ MCS5 20 MHz Typ. -70 dBm @ MCS6 20 MHz Typ. -69 dBm @ MCS7 20 MHz Typ. -95 dBm @ MCS8 20 MHz Typ. -91 dBm @ MCS9 20 MHz Typ. -87 dBm @ MCS10 20 MHz Typ. -80 dBm @ MCS11 20 MHz Typ. -78 dBm @ MCS12 20 MHz Typ. -74 dBm @ MCS13 20 MHz Typ. -72 dBm @ MCS14 20 MHz Typ. -71 dBm @ MCS15 20 MHz Typ. -84 dBm @ MCS0 40 MHz Typ. -81 dBm @ MCS1 40 MHz Typ. -77 dBm @ MCS2 40 MHz Typ. -75 dBm @ MCS3 40 MHz Typ. -71 dBm @ MCS4 40 MHz Typ. -67 dBm @ MCS5 40 MHz Typ. -64 dBm @ MCS6 40 MHz</p>

5. Due to a limitation in the receiver sensitivity performance for channels 153 and 161, it is recommended to avoid using these channels in your critical applications.

	<p>Typ. -63 dBm @ MCS7 40 MHz Typ. -90 dBm @ MCS8 40 MHz Typ. -85 dBm @ MCS9 40 MHz Typ. -82 dBm @ MCS10 40 MHz Typ. -81 dBm @ MCS11 40 MHz Typ. -77 dBm @ MCS12 40 MHz Typ. -73 dBm @ MCS13 40 MHz Typ. -71 dBm @ MCS14 40 MHz Note⁶ Typ. -68 dBm @ MCS15 40 MHz</p>
Receiver Sensitivity for 802.11b (measured at 2.437 GHz)	<p>Typ. -93 dBm @ 1 Mbps Typ. -93 dBm @ 2 Mbps Typ. -93 dBm @ 5.5 Mbps Typ. -88 dBm @ 11 Mbps</p>
Receiver Sensitivity for 802.11g (measured at 2.437 GHz)	<p>Typ. -88 dBm @ 6 Mbps Typ. -86 dBm @ 9 Mbps Typ. -85 dBm @ 12 Mbps Typ. -85 dBm @ 18 Mbps Typ. -85 dBm @ 24 Mbps Typ. -82 dBm @ 36 Mbps Typ. -78 dBm @ 48 Mbps Typ. -74 dBm @ 54 Mbps</p>
Receiver Sensitivity for 802.11n (2.4 GHz; measured at 2.437 GHz)	<p>Typ. -89 dBm @ MCS0 20 MHz Typ. -85 dBm @ MCS1 20 MHz Typ. -85 dBm @ MCS2 20 MHz Typ. -82 dBm @ MCS3 20 MHz Typ. -78 dBm @ MCS4 20 MHz Typ. -74 dBm @ MCS5 20 MHz Typ. -72 dBm @ MCS6 20 MHz Typ. -70 dBm @ MCS7 20 MHz Typ. -95 dBm @ MCS8 20 MHz Typ. -90 dBm @ MCS9 20 MHz Typ. -87 dBm @ MCS10 20 MHz Typ. -83 dBm @ MCS11 20 MHz Typ. -80 dBm @ MCS12 20 MHz Typ. -74 dBm @ MCS13 20 MHz Typ. -71 dBm @ MCS14 20 MHz Typ. -69 dBm @ MCS15 20 MHz Typ. -87 dBm @ MCS0 40 MHz Typ. -83 dBm @ MCS1 40 MHz Typ. -83 dBm @ MCS2 40 MHz Typ. -80 dBm @ MCS3 40 MHz Typ. -76 dBm @ MCS4 40 MHz Typ. -73 dBm @ MCS5 40 MHz Typ. -69 dBm @ MCS6 40 MHz Typ. -67 dBm @ MCS7 40 MHz Typ. -93 dBm @ MCS8 40 MHz Typ. -88 dBm @ MCS9 40 MHz Typ. -85 dBm @ MCS10 40 MHz Typ. -82 dBm @ MCS11 40 MHz Typ. -78 dBm @ MCS12 40 MHz Typ. -73 dBm @ MCS13 40 MHz Typ. -69 dBm @ MCS14 40 MHz Typ. -67 dBm @ MCS15 40 MHz</p>
WLAN Operation Mode	Access point, Client, Client-Router, Sniffer
Antenna Connectors	QMA
Ethernet Interface	
PoE Ports (10/100BaseT(X), M12 D-coded 4-pin female connector)	1, AWK-3131A-M12-RTG only
Standards	<p>IEEE 802.3 for 10BaseT IEEE 802.3u for 100BaseT(X) IEEE 802.3af for PoE IEEE 802.1Q for VLAN Tagging</p>

6. Due to a limitation in the receiver sensitivity performance for channels 153 and 161, it is recommended to avoid using these channels in your critical applications.

10/100BaseT(X) Ports (M12 D-coded 4-pin female connector)	1, 10/100BaseT(X) auto negotiation speed, F/H duplex mode, and auto MDI/MDI-X connection (AWK-3131A-M12-RTG only)	
100BaseFX Ports (single-mode SC connector)	1, AWK-3131A-SSC-RTG only	
Optical Fiber	100BaseFX	
	Wavelength	1310 nm
	Max. TX	0 dBm
	Min. TX	-5 dBm
	RX Sensitivity	-34 dBm
	Link Budget	29 dB
	Typical Distance	40 km

Ethernet Software Features

Management	General: Proxy ARP, DNS, HTTP, HTTPS, IP, ICMP, SNTP, TCP, UDP, RADIUS, SNMP, PPPoE, DHCP AP-only: ARP, BOOTP, DHCP, STP/RSTP (IEEE 802.1D/w)
Security	RADIUS

Firewall

Filter	MAC/IP Protocol/Port-based
--------	----------------------------

Serial Interface

Console Port	RS-232 (RJ45-type)
--------------	--------------------

LED Interface

LED Indicators	PWR1, PWR2, PoE*, FAULT, STATE, SIGNAL, CLIENT, WLAN, LAN (AWK-3131A-M12-RTG only), 100M (AWK-3131A-SSC-RTG only) *PoE is only available for the AWK-3131A-M12-RTG
----------------	---

Input/Output Interface

Digital Inputs	2 +13 to +30 V for state 1 +3 to -30 V for state 0 Max. input current: 8 mA
Alarm Contact Channels	Relay output with current carrying capacity of 1 A @ 24 VDC
Buttons	Reset button

Physical Characteristics

Housing	Metal
IP Rating	IP30
Dimensions	52.9 x 151.9 x 127.4 mm (2.08 x 5.98 x 5.02 in)
Weight	850 g (1.87 lb)
Installation	DIN-rail mounting, Wall mounting (with optional kit)

Power Parameters

Input Current	AWK-3131A-M12-RTG: 0.85 A @ 12 VDC, 0.22 A @ 48 VDC AWK-3131A-SSC-RTG: 1.0 A @ 12 VDC, 0.27 A @ 48 VDC
Input Voltage	12 to 48 VDC, Redundant dual inputs, 48 VDC Power-over-Ethernet

Power Connector	1 removable 10-contact terminal block(s)
Power Consumption	AWK-3131A-M12-RTG: Maximum 10.5 W AWK-3131A-SSC-RTG: Maximum 13 W
Reverse Polarity Protection	Supported
Environmental Limits	
Operating Temperature	Wide Temp. Models: -40 to 75°C (-40 to 167°F)
Storage Temperature (package included)	-40 to 85°C (-40 to 185°F)
Ambient Relative Humidity	5 to 95% (non-condensing)
Standards and Certifications	
EMC	EN 61000-6-2/-6-4
EMI	CISPR 32, FCC Part 15B Class B
EMS	IEC 61000-4-2 ESD: Contact: 8 kV; Air: 15 kV IEC 61000-4-3 RS: 80 MHz to 1 GHz: 20 V/m IEC 61000-4-4 EFT: Power: 2 kV; Signal: 2 kV IEC 61000-4-5 Surge: Power: 2 kV; Signal: 2 kV IEC 61000-4-6 CS: 10 V IEC 61000-4-8
Railway	EN 50155, EN 50121-4
Railway Fire Protection	EN 45545-2
Radio	EN 301 489-1/17, EN 300 328, EN 301 893, MIC, FCC ID SLE-WAPN008, SRRC, NCC, IDA
Safety	UL 60950-1, IEC 60950-1, EN 60950-1 (LVD)
MTBF	
Time	AWK-3131A-M12-RTG: 552,454 hrs AWK-3131A-SSC-RTG: 528,478 hrs
Standards	Telcordia SR332
Warranty	
Warranty Period	5 years
Details	See www.moxa.com/warranty
Package Contents	
Device	1 x AWK-3131A-RTG wireless AP/client
Installation Kit	1 x DIN-rail kit 2 x cap, plastic, for RJ45 port 1 plastic protective cap for fiber port (AWK-3131A-SSC-RTG only) 1 x cable holder with screw
Documentation	1 x quick installation guide 1 x warranty card

Dimensions

AWK-3131A-M12-RTG Models

Unit: mm (inch)

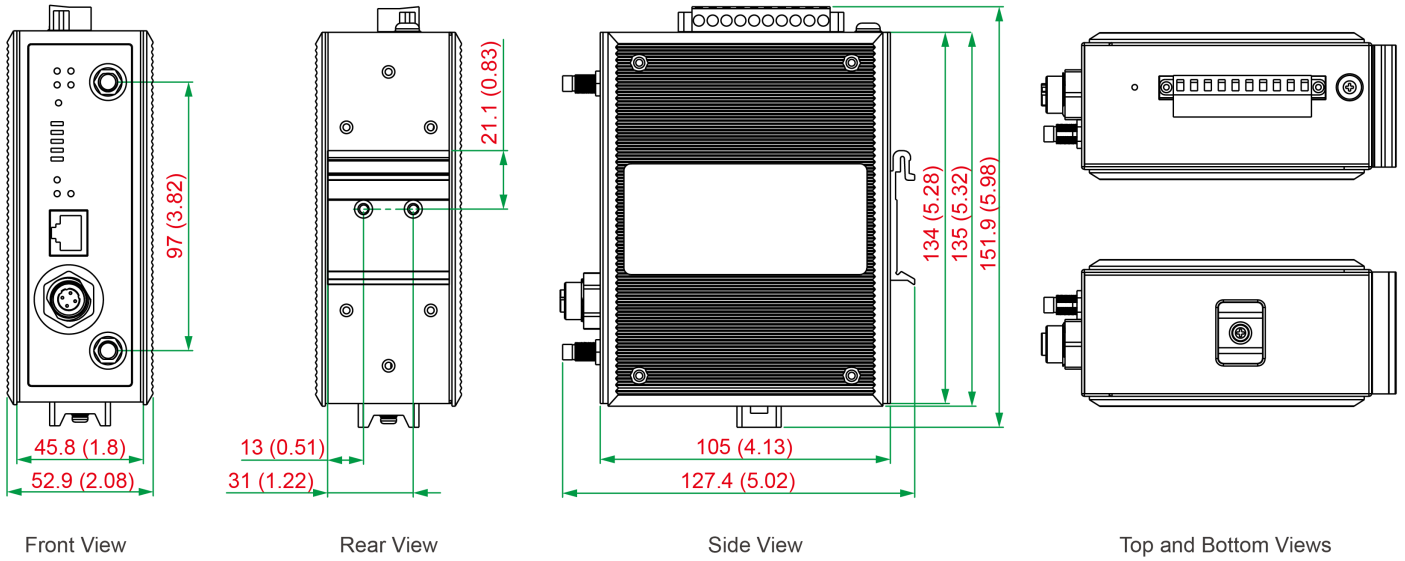

AWK-3131A-SSC-RTG Models

Unit: mm (inch)

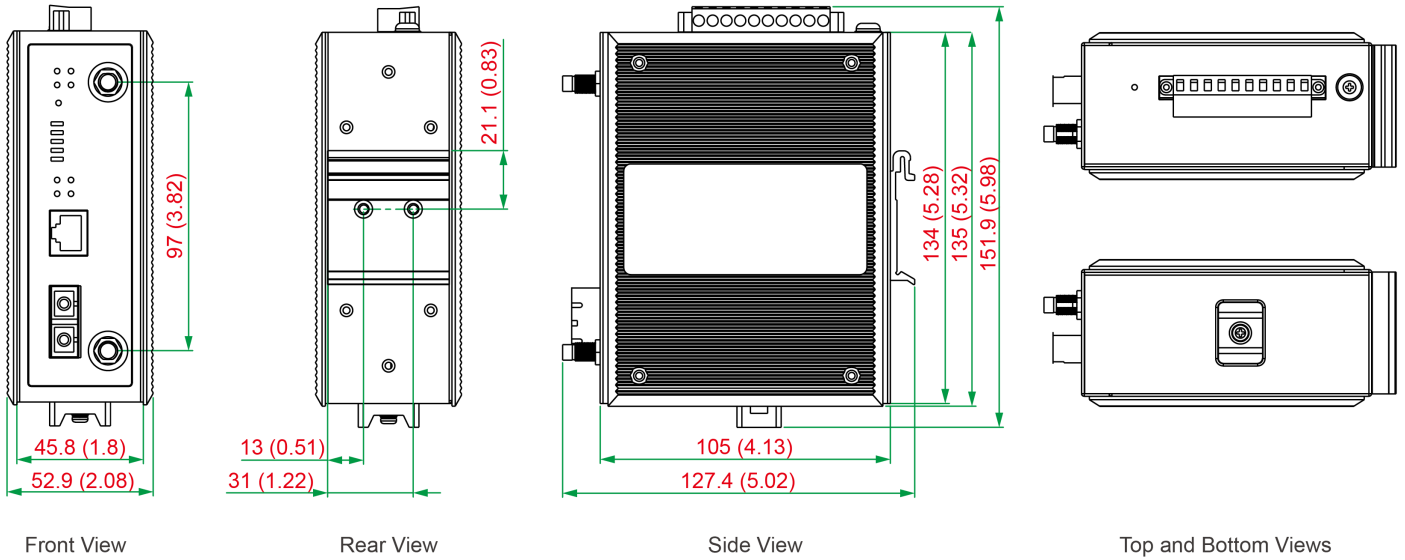

Ordering Information

Model Name	Band	Connector	Conformal Coating
AWK-3131A-M12-RTG-EU-T	EU	M12	-
AWK-3131A-M12-RTG-US-T	US	M12	-
AWK-3131A-M12-RTG-JP-T	JP	M12	-
AWK-3131A-M12-RTG-EU-CT-T	EU	M12	✓
AWK-3131A-M12-RTG-US-CT-T	US	M12	✓
AWK-3131A-M12-RTG-JP-CT-T	JP	M12	✓
AWK-3131A-SSC-RTG-EU-T	EU	Single-mode SC	-
AWK-3131A-SSC-RTG-US-T	US	Single-mode SC	-
AWK-3131A-SSC-RTG-JP-T	JP	Single-mode SC	-

Model Name	Band	Connector	Conformal Coating
AWK-3131A-SSC-RTG-EU-CT-T	EU	Single-mode SC	✓
AWK-3131A-SSC-RTG-US-CT-T	US	Single-mode SC	✓
AWK-3131A-SSC-RTG-JP-CT-T	JP	Single-mode SC	✓

Accessories (sold separately)

Wall-Mounting Kits

WK-51-01	Wall mounting kit with 2 plates (51.6 x 67 x 2 mm) and 6 screws
----------	---

© Moxa Inc. All rights reserved. Updated Aug 20, 2019.

This document and any portion thereof may not be reproduced or used in any manner whatsoever without the express written permission of Moxa Inc. Product specifications subject to change without notice. Visit our website for the most up-to-date product information.