



ALLIOLiGHT Systemleuchten

Türpositionsschalter

zu den Serien ALLIO und ALU-LINE

- Einfache Positionseinrichtung
- Flache, platzsparende Ausführung
- Zuverlässiges, direktes Schalten
- Integrierte Kabelführung
- Montage auf Flächen und Profilen verschiedener Hersteller
- Montagehilfe durch Einrasten in Profilen
- Auch für außenliegende Türen
- Mit Anschlussleitung 0,6 m und geradem Stecker
- Adapter für Schaltschränke von Rittal, Hofmann, Eldon und Triton sowie für Montage auf Flächen sind im Lieferumfang enthalten

Ausführung mit 0,6 m Anschlussleitung und geradem Stecker

Art.-Nr. 81132

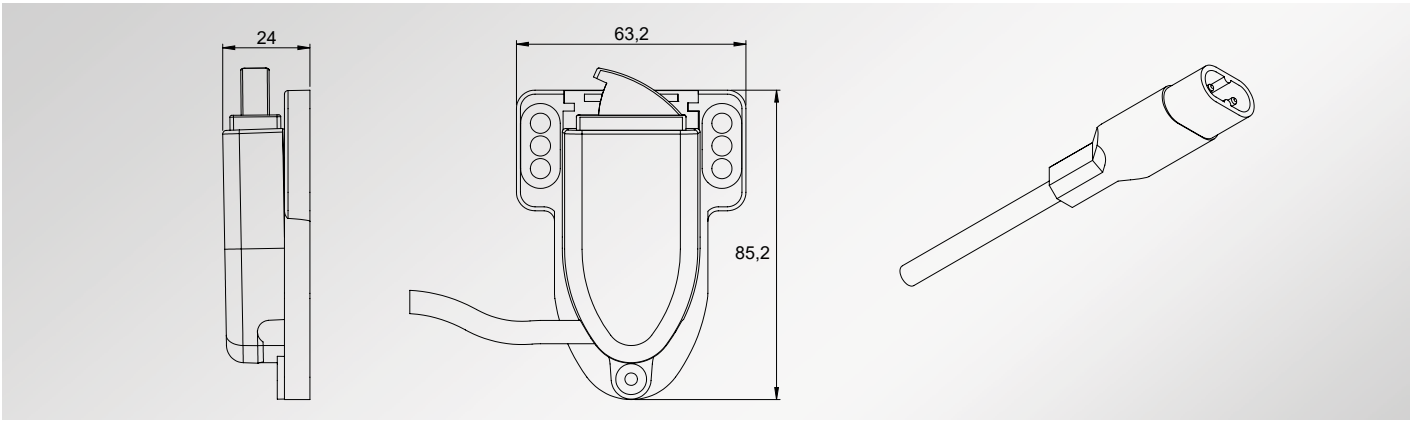

Montagevarianten



Einrasten (Montagehilfe) und Schrauben auf Profilen



Schrauben auf Flächen

Adapter für die Montage



Adapter 0

Adapter T2/E2 (für Triton/Eldon)

Adapter E1 (für Eldon)

Adapter R1 (für Rittal)

Spezifikationen

Art.-Nr. 81132	
Elektrische Anschlusswerte	
Nennspannung	250 V AC, 25 W
Potenzialfreier Kontakt	2-poliger Gerätestecker; 2,5 A
Anschlussleitung	2 x 0,75 mm ² ; 0,6 m; Mantelfarbe schwarz
Schutzart/Schutzklasse	
Schutzart	IP20
Schutzklasse	II (Schutzisolierung)

Art.-Nr. 81132	
Weitere Daten	
Kennzeichnung	CE, UKCA
Abmessungen	95 x 63 x 24 mm
Gewicht	150 g
Betriebstemperatur	-20 °C bis +50 °C



ALLIOLiGHT lighting systems

Door operated switch

suitable for ALLIO and ALU-LINE series

- Easy adjustment
- Flat, space-saving design
- Reliable, direct switching
- Integrated cable routing
- Assembly on surfaces and profiles of various manufacturers
- Snap-on assembly aid on profiles
- Also suitable for exterior doors
- With 0.6 m connecting cable and straight connector
- Adapters for enclosures from Rittal, Hofmann, Eldon and Triton as well as for assembly on surfaces are included in the scope of delivery

Version with 0.6 m connecting cable and straight connector

Order No. 81132

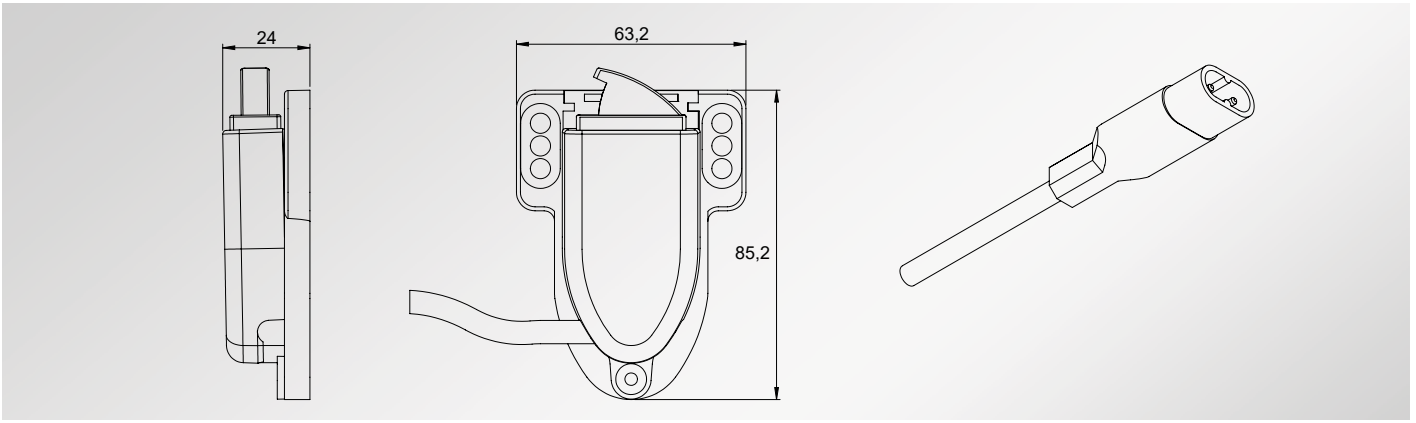

Assembly options



Snap-on assembly aid and screw-on assembly on profiles



Screw assembly on surfaces

Adapters for assembly



Specifications

81132	
Technical data	
Rated voltage	250 V AC, 25 W
Contact for door operated switch	via 2-pole mini-connector, 2.5 A
Connecting cable	2 x 0.75 mm ² ; 0.6 m; colour black
Protection class/category	
Protection class	IP20
Protection category	II (Protective insulation)

81132	
Other specifications	
Labelling	CE, UKCA
Dimensions L x W x H	95 x 63 x 24 mm
Weight	150 g
Operating temperature	-20 °C to +50 °C