

Data sheet

Art.No.: 96.071.4553.1

connector RST20I7S B1 ZR3 SW

RST® CLASSIC connector, straight, number of poles 7, female, connection type screw connection, rated voltage 250 V / 400 V, rated current 20 A, cable diameter 13 - 18 mm, color of coding/ contact carrier black



Art.No.	96.071.4553.1
EAN	4049088423963
Order Unit	1

certificates / approvals



RINA



Technical data

general

rated current	20 A
rated voltage	250 V / 400 V
rated impulse voltage	4 kV
strain relief	yes
pollution degree	3
lockable	self-locking (unlocking by tool)
color of coding/ contact carrier	black
Pole codification	1, 2, 3, 4/N, 5, 6, PE
color of housing inclusive strain relief	black
RAL-Nummer Codierung/Kontakteinsatz	9005

connection data

cable diameter max.	18 mm
cable diameter min.	13 mm
connection cross section solid mm ² max.	1.5 mm ²
connection cross section solid mm ² min.	0.2 mm ²
connection cross section fine stranded mm ² max.	2.5 mm ²
connection cross section fine stranded mm ² min.	0.2 mm ²
terminations per pole	1
sheath strip length	37 mm
wire strip length	8 mm

technical data UL

connection cross section stranded AWG min.	20 AWG
UL classification housing	UL-V2

UL classification strain relief	UL-V2
---------------------------------	-------

model

model	female
connection type	screw connection
degree of protection (IP)	IP66/68 (3m;2h) /IP69

material

housing material	polyamide
halogen free	yes
contact material	CuZn
fire load	0.399 kWh/St
insulation components continuous temperature	100 °C
surface finish	silver-plated

dimensions

length	102 mm
width	35.4 mm
height	35.4 mm

note

note	wires with 2.5 mm ² only without ferrules; 3 poles max. 20A, 4 poles max. 5A
------	---

classification

ECLASS 11	
ECLASS 8.1	27440605
ETIM 9.0	EC002560
ETIM 8.0	EC002560
ETIM 7.0	EC002560
ETIM 6.0	EC002560
ETIM 5.0	EC002560
ETIM 4.0	EC002560

product compliance

ROHS conformity status	compliant/exempted
ROHS exceptions	III-6(c)
REACH-SVHC conformity status	Duty-To-Declare
REACH-SVHC substances	Lead
REACH-SVHC CAS numbers	7439-92-1

A
Weitergabe sowie Vervielfältigung dieses Dokuments, Verwertung und Mitteilung seines Inhalts sind verboten, soweit nicht ausdrücklich gestattet. The reproduction, distribution and utilization of this document as well as the communication of its contents to others without express authorization is prohibited.

B
These dimensions will be especially checked at delivery
Only inspection dimensions
With /E marked dimensions are only valid for internal use

D
Diese Maße werden bei Abnahme besonders geprüft
Ausschließlich Prüfmaße
Mit /E gekennzeichnete Maße sind nur für interne Zwecke gültig

F

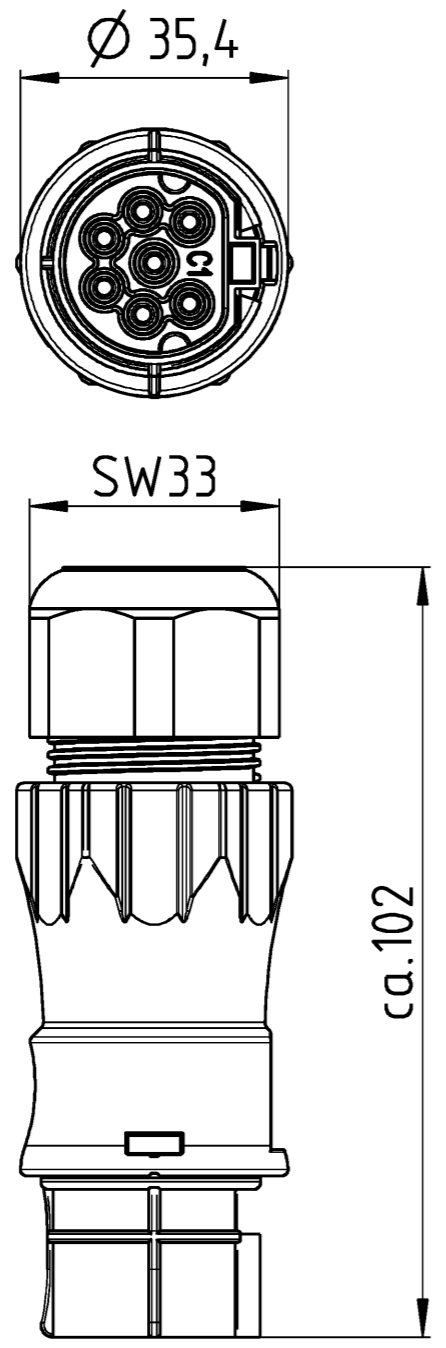

Auslieferungszustand / delivery status

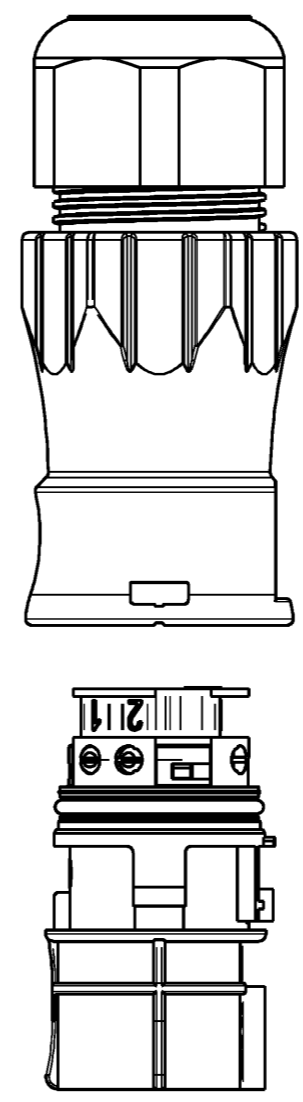

Teile-Nr./ Part no.	Typ/ Type		Kodierung/ coding
96.071.4553.0	RST2017S B1 ZR3	GL	
96.071.4553.1	RST2017S B1 ZR3	SW	
9L.071.4553.0	RST2017S 11 ZR3	GL	
9L.071.4553.1	RST2017S 11 ZR3	SW	
96.071.4553.9	RST2017S B1 ZR3	BL07	
9L.071.4553.9	RST2017S 11 ZR3	BL07	
96.061.4553.6	RST2016S B1 ZR3	TB04	
9L.061.4553.6	RST2016S 11 ZR3	TB04	
96.071.4553.6	RST2017S B1 ZR3	TB04	
9L.071.4553.6	RST2017S 11 ZR3	TB04	

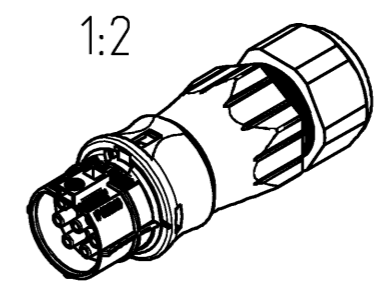

● = Pol verschlossen / pole closed

Tolerierung Size ISO 14405 (E) / Tolerance system Size ISO 14405 (E). (This ISO-standard describes the envelope principle. According to the envelope principle the deviations of form and parallelism are limited by the size tolerances).		ja/yes <input checked="" type="checkbox"/> Stoffverbots- und Deklarationsliste nach WN 5020.010 ist einzuhalten. Conformity with Wieland document WN 5020.010 e (list of prohibited / declarable hazardous substances) to be declared!	
Freitoleranz nach General tolerance		CAD - Zeichnung, keine manuellen Änderungen CAD - drawing, no manual modifications allowed	1. Verwendung: First Use:
Blatt: 1 von 1 Sheet: of			
Werkstoff / Material		Tag/Date	Name
Maßstab / Scale		gezeichnet/drawn	16.11.2017 Hollet
1:1		geprüft/checked	
Vol. mm ³ Dfl./Srf. mm ²		Normgepr. / Stand. check	
Ersatz für / Replacement for:		Zeichnung Nr. / Drawing No.	
		96.071.4553.0 13K a	
Maße in mm / Dimensions are in mm			
Type		Benennung/Title	
a 14.05.2018 /		RST201	
Index Datum / Blatt Date / Sheet		BU_SCHRAUB	
Änderung / Revision		ohne Drahtschutz	
www.wieland-electric.com		female, screw connection without wire protection	