

# PTC-101 Series

## IEC 61850-3 and railway Ethernet-to-fiber media converters



- > 10/100BaseT(X) auto-negotiation and auto-MDI/MDI-X
- > Link Fault Pass-Through (LFP)
- > Power failure alarm by relay output (LV model only)
- > -40 to 85°C operating temperature range
- > Redundant dual DC power inputs (LV model only)
- > Integrated high-reliability power supply eliminates the need for external power transformer
- > Compliant with EN 50121-4
- > Complies with all EN 50155 mandatory test items\*

\*This product is suitable for rolling stock railway applications, as defined by the EN 50155 standard. For a more detailed statement, click here: [www.moxa.com/doc/specs/EN\\_50155\\_Compliance.pdf](http://www.moxa.com/doc/specs/EN_50155_Compliance.pdf)



### Introduction

The PTC-101 Ethernet-to-fiber media converters convert from 10/100BaseT(X) to 100BaseFX. Models are available with either SC, ST, or LC connectors. The PTC-101 converters eliminate the need for additional wiring, and support IEEE 802.3 and IEEE 802.3u/x protocols with 10/100M, full/half-duplex, and MDI/MDI-X auto-sensing

to provide a total solution for your industrial Ethernet networks. The PTC-101 is compliant with mandatory sections of EN 50155, covering operating temperature, power input voltage, surge, ESD, and vibration, as well as conformal coating and power insulation, making the switches suitable for a variety of industrial applications.

### Specifications

#### Technology

##### Standards:

IEEE 802.3 for 10BaseT

IEEE 802.3u for 100BaseT(X), 100BaseFX

##### Interface

**RJ45/M12 Ports:** 10/100BaseT(X)

**Fiber Ports:** 100BaseFX (SC/ST/LC connectors)

**LED Indicators:** PWR1, PWR2, Fiber Link, 10/100M (TP port)

##### DIP Switches:

DIP No.	Function	ON	OFF
1	Auto Negotiation	Enable	Disable
2	Force TP Speed	100 Mbps	10 Mbps
3	Force TP Duplex	Full Duplex	Half Duplex
4	Link Fault Pass Through	Enable	Disable
5	Operating Mode	Store-and-Forward	Pass Through

The default setting for all DIP switches is ON.

**Alarm Contact:** One relay output with current carrying capacity of 1 A @ 24 VDC (LV model only)

#### Optical Fiber

		100BaseFX		
		Multi-Mode		Single-Mode
Fiber Cable Type		OM1	50/125 μm 800 MHz*km	G. 652
Typical Distance		4 km	5 km	40 km
Wave-length	Typical (nm)	1300		1310
	TX Range (nm)	1260 to 1360		1280 to 1340
	RX Range (nm)	1100 to 1600		1100 to 1600
Optical Power	TX Range (dBm)	-10 to -20		0 to -5
	RX Range (dBm)	-3 to -32		-3 to -34
	Link Budget (dB)	12		29
	Dispersion Penalty (dB)	3		1

Note: When connecting a single-mode fiber transceiver, we recommend using an attenuator to prevent damage caused by excessive optical power.

Note: Compute the "typical distance" of a specific fiber transceiver as follows: Link budget (dB) > dispersion penalty (dB) + total link loss (dB).

#### Physical Characteristics

**Housing:** Metal, IP30 protection

**Dimensions:** 152.15 x 123.46 x 66.65 mm (5.99 x 4.86 x 2.62 in)

##### Weight:

Product only: 690 g (1.52 lb)

Packaged: 875 g (1.92 lb)

#### Environmental Limits

**Operating Temperature:** -40 to 85°C (-40 to 185°F)

**Storage Temperature:** -40 to 85°C (-40 to 185°F)

**Ambient Relative Humidity:** 5 to 95% (non-condensing)

**Conformal Coating:** Available upon request

## Power Requirements

### Input Voltage:

Power Supply Type	Power Consumption	Fuse Rating
LV - DC	20 to 72 VDC	170 mA @ 20 VDC
HV - AC	85 to 264 VAC	73 mA @ 85 VAC
HV - DC	88 to 300 VDC	47 mA @ 88 VDC

V-DC compliant with EN 50155 on 48 VDC  
 HV-DC compliant with EN 50155 on 110 VDC

### Input Current:

LV-DC: 170 mA @ 20 VDC max.

HV-AC: 73 mA @ 85 VDC max.

HV-DC: 47 mA @ 88 VDC max.

**Connection:** Removable terminal block

**Overload Current Protection:** 1.6 A (protects against two signals shorted together)

**Reverse Polarity Protection:** Protects against V+/V- reversal

## Standards and Certifications

**Safety:** UL 60950-1

**EMC:** EN 55032/24

**EMI:** CISPR 32, FCC Part 15B Class A

### EMS:

EN 61000-4-2 (ESD): Contact: 8 kV; Air: 15 kV

EN 61000-4-3 (RS): 80 MHz to 1 GHz: 3 V/m

EN 61000-4-4 (EFT): Power: 4 kV; Signal: 4 kV

EN 61000-4-5 (Surge): Power: 4 kV; Signal: 4 kV

EN 61000-4-6 (CS): 150 kHz to 80 MHz: 3 V/m

EN 61000-4-8 (PFMF)

EN 61000-4-11

**Green Product:** RoHS, CRoHS, WEEE

*Note: Refer to the "Environmental Type Tests" table below for more detailed information.*

**Freefall:** IEC 60068-2-32

**Power Automation:** IEC 61850-3, IEEE 1613

**Rail Traffic:** EN 50121-4

*\*Please contact Moxa or a Moxa distributor for details.*

**Vibration:** IEC-61850-3, IEC-60870-2-2, EN 50125-3 (M12 models only)

**MTBF** (mean time between failures)

**Time:** 1,211,613 hrs

**Standard:** Telcordia (Bellcore), GB

## Warranty

**Warranty Period:** 5 years

**Details:** See [www.moxa.com/warranty](http://www.moxa.com/warranty)

Environmental Type Tests			
Test	Description		Test Levels
IEC 60068-2-1	Cold, operating (power ON/OFF)	Test Ad	-40°C, 48 hours
IEC 60068-2-3	Damp heat, steady state, operating	Test Ca	85°C, 95% R.H., 24 hours
IEC 60068-2-14	Changing temperature, operating	Test Nb	-40 to 85°C, Ramp rate: 3°C/min, 8 cycles
IEC 60068-2-48	Cold, storage	Test Ad	-40°C, 12 hours
IEC 60068-2-1			
IEC 60068-2-48	Damp heat, steady state, storage	Test Ca	90°C, 95% R.H., 24 hours
IEC 60068-2-3			
IEC 60068-2-32	Freefall, package	Test Ed	90 cm
ISTA-2A			
IEC 60068-2-34	Random vibration, package	Test Fd	3 grms (5 to 500 Hz)
IEC 61850-3	Vibration, operating	Class Cm (3M6, 4M6)	20 m/s <sup>2</sup> (9 to 200 Hz) 15 m/s <sup>2</sup> (200 to 500 Hz)
IEC 60870-2-2			
IEC 60068-2-6			
IEC 60721-3-3			
IEC 61850-3	Shock, operating	Class Cm (3M6, 4M6)	300 m/s <sup>2</sup> , 11 ms
IEC 60870-2-2			
IEC 60068-2-27			
IEC 60721-3-3			

## Dimensions

### PTC-101-M-ST-HV (other models available by request)

Unit: mm (inch)

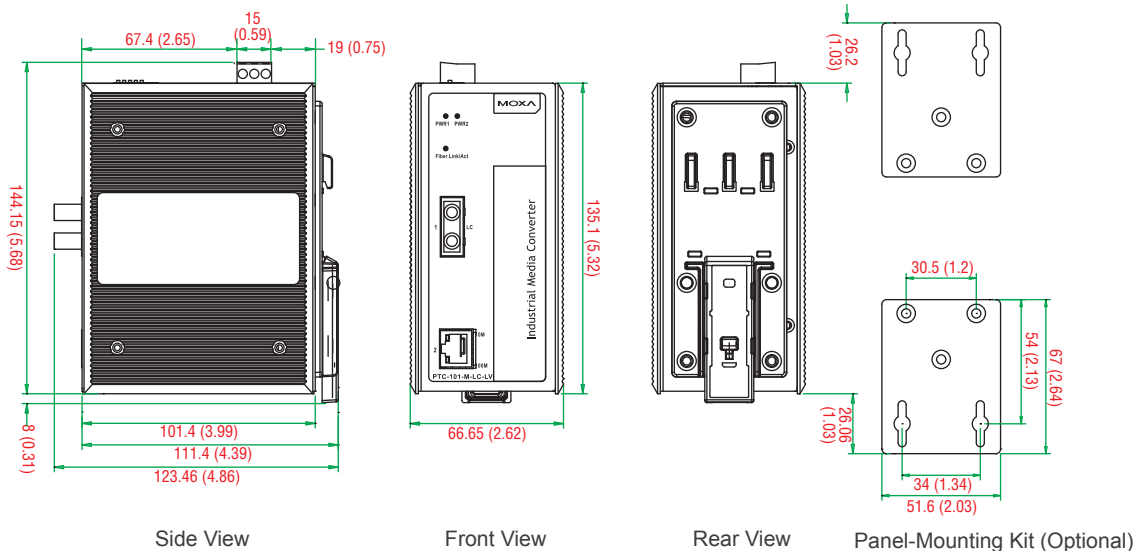

**Dimensions**

**PTC-101-M12**

Unit: mm (inch)

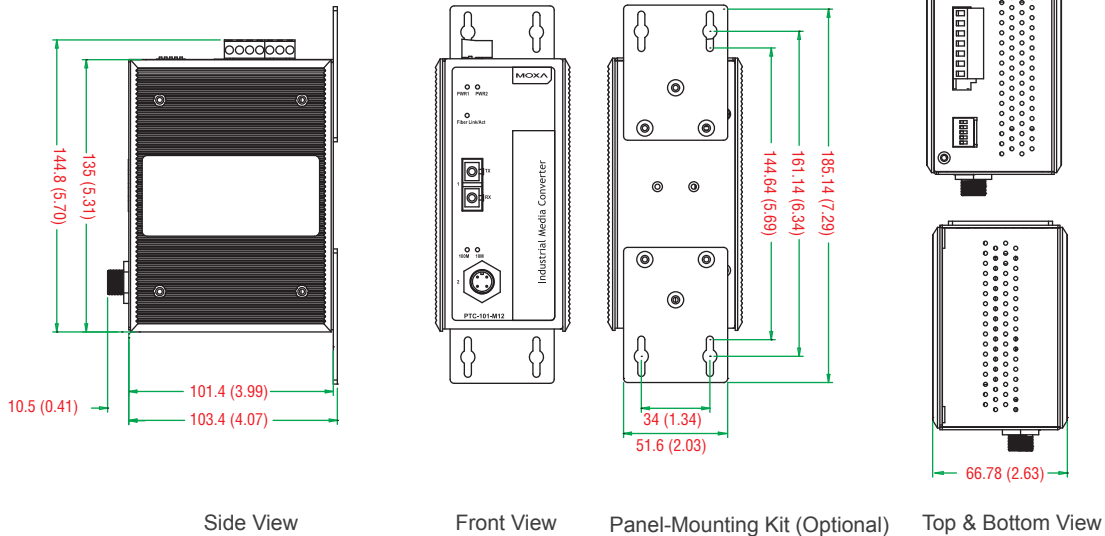

**Ordering Information**

**Available Models**

- PTC-101-M-SC-LV:** Industrial 10/100BaseT(X) to 100BaseFX media converter, multi-mode with SC connector, dual redundant power inputs (20-72 VDC), -40 to 85°C operating temperature
- PTC-101-M-ST-LV:** Industrial 10/100BaseT(X) to 100BaseFX media converter, multi-mode with ST connector, dual redundant power inputs (20-72 VDC), -40 to 85°C operating temperature
- PTC-101-M-LC-LV:** Industrial 10/100BaseT(X) to 100BaseFX media converter, multi-mode with LC connector, dual redundant power inputs (20-72 VDC), -40 to 85°C operating temperature
- PTC-101-S-SC-LV:** Industrial 10/100BaseT(X) to 100BaseFX media converter, single-mode with SC connector, dual redundant power inputs (20-72 VDC), -40 to 85°C operating temperature
- PTC-101-S-ST-LV:** Industrial 10/100BaseT(X) to 100BaseFX media converter, single-mode with ST connector, dual redundant power inputs (20-72 VDC), -40 to 85°C operating temperature
- PTC-101-S-LC-LV:** Industrial 10/100BaseT(X) to 100BaseFX media converter, single-mode with LC connector, dual redundant power inputs (20-72 VDC), -40 to 85°C operating temperature
- PTC-101-M-SC-HV:** Industrial 10/100BaseT(X) to 100BaseFX media converter, multi-mode with SC connector, 1 isolated power supply (88-300 VDC or 85-264 VAC), -40 to 85°C operating temperature
- PTC-101-M-ST-HV:** Industrial 10/100BaseT(X) to 100BaseFX media converter, multi-mode with ST connector, 1 isolated power supply (88-300 VDC or 85-264 VAC), -40 to 85°C operating temperature
- PTC-101-M-LC-HV:** Industrial 10/100BaseT(X) to 100BaseFX media converter, multi-mode with LC connector, 1 isolated power supply (88-300 VDC or 85-264 VAC), -40 to 85°C operating temperature
- PTC-101-S-SC-HV:** Industrial 10/100BaseT(X) to 100BaseFX media converter, single-mode with SC connector, 1 isolated power supply (88-300 VDC or 85-264 VAC), -40 to 85°C operating temperature
- PTC-101-S-ST-HV:** Industrial 10/100BaseT(X) to 100BaseFX media converter, single-mode with ST connector, 1 isolated power supply (88-300 VDC or 85-264 VAC), -40 to 85°C operating temperature
- PTC-101-S-LC-HV:** Industrial 10/100BaseT(X) to 100BaseFX media converter, single-mode with LC connector, 1 isolated power supply (88-300 VDC or 85-264 VAC), -40 to 85°C operating temperature
- PTC-101-M12-S-SC-LV-T:** Industrial 10/100BaseT(X) to 100BaseFX media converter, M12 connector, single-mode with SC connector (20-72 VDC), -40 to 85°C operating temperature
- PTC-101-M12-S-ST-LV-T:** Industrial 10/100BaseT(X) to 100BaseFX media converter, M12 connector, single-mode with ST connector (20-72 VDC), -40 to 85°C operating temperature
- PTC-101-M12-S-SC-LV-T-CT:** Industrial 10/100BaseT(X) to 100BaseFX media converter, M12 connector, single-mode with SC connector (20-72 VDC), -40 to 85°C operating temperature, conformal coating
- PTC-101-M12-S-ST-LV-T-CT:** Industrial 10/100BaseT(X) to 100BaseFX media converter, M12 connector, single-mode with ST connector (20-72 VDC), -40 to 85°C operating temperature, conformal coating

**Optional Accessories** (can be purchased separately)

- WK-51:** Wall-mounting kit
- DK-DC50131:** DIN-rail mounting kit
- WK-51-01:** DIN-rail/wall-mounting kit, 2 plates with 6 screws
- DK-DC50131-01:** DIN-rail mounting kit, 2 plates with 8 screws

**Package Checklist**

- 1 PTC-101 media converter
- Hardware installation guide (printed)
- Warranty card